

# Septic Tank Sludge Treatment Plant WASTEMASTER TSB4



# COMPACT PLANT FOR SLUDGE FROM SEPTIC TANKS

WASTEMASTER TSB4 carries out up to 4 different processes in a single compact plant:

- 1) Screening
- 2) De-gritting
- 3) De-greasing
- 4) Compacting

Sewage from septic tanks or industrial plants collected in by special tankers has to be treated before being introduced into any kind of purification system.

For the WASTEMASTER TSB4 system two highly innovative technologies have been introduced:

- A multi-screw system in SINT® engineering polymer for screening called POLYSCREW™
- A floating screw system manufactured from SINT® engineering polymer for removal of floating matter.

The WASTEMASTER TSB4 plant is equipped with electronic and electric components (control panels, acoustic and visual malfunction alarm, solenoid valves, blowers) to ensure problem-free operation during both waste discharge and work cycle of the machine.

## Overall Dimensions

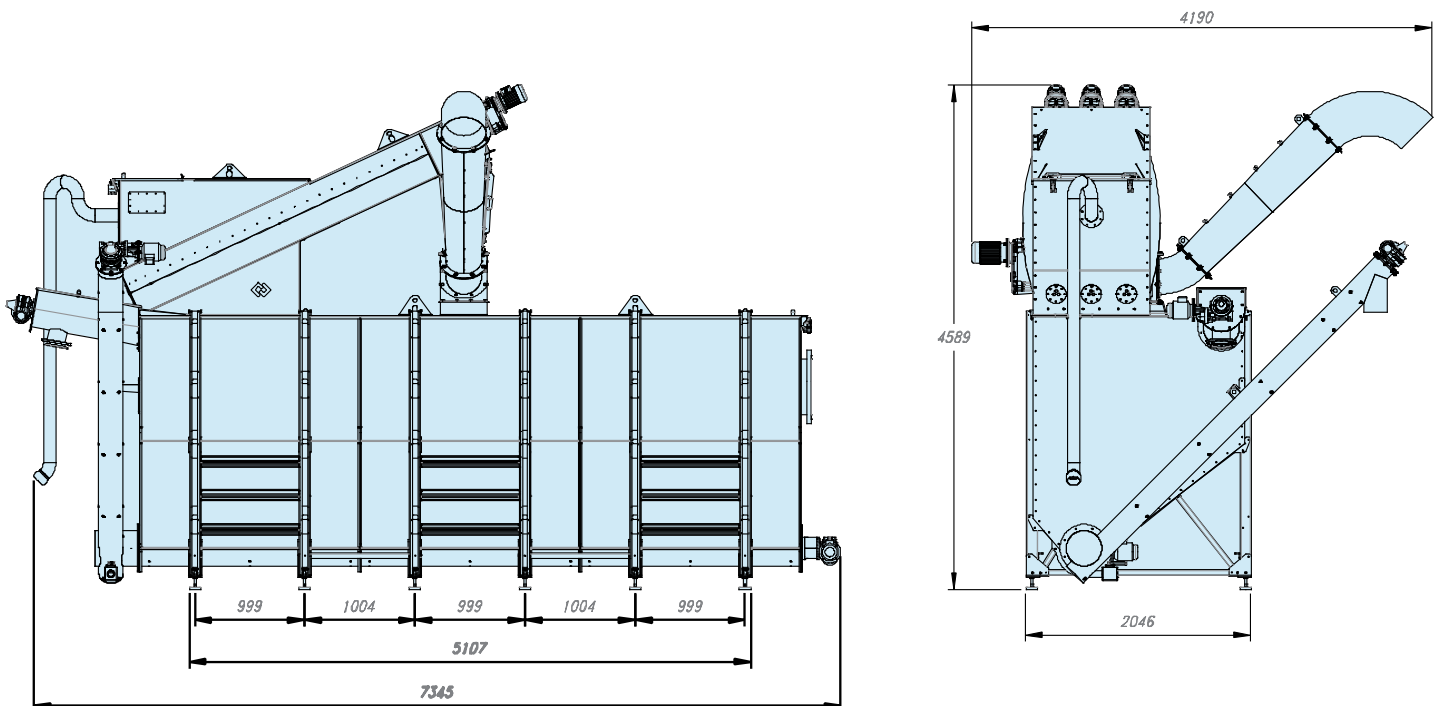

Dimensions in mm

## Benefits

- ✓ **Screening, de-gritting, de-greasing, compacting in a single unit;**
- ✓ **Easy installation, low maintenance and low operating costs;**
- ✓ **Outdoor installation with optional anti-freeze accessories;**
- ✓ **No clogging even with fibres thanks to shaftless screw design;**
- ✓ **Odour free;**
- ✓ **No civil works required.**

## Technical features

- WASTEMASTER TSB4 has a sturdy metal framework, manufactured entirely from 304L / 316L stainless steel
- Zero clearance between helicoid flighting and the polyurethane screen trough enables the removal of smallest fibres and hair
- The maximum flow rate is approximately 60 m<sup>3</sup>/h for waste water with a solid percentage higher than 15%
- WASTEMASTER TSB4 is equipped with electronic and electric components (control panels, acoustic and visual malfunction alarm, solenoid valves, blowers)
- The floating SINT® engineering polymer screw ensures high removal of floating matter



Jagged multi-screw with SINT® screen

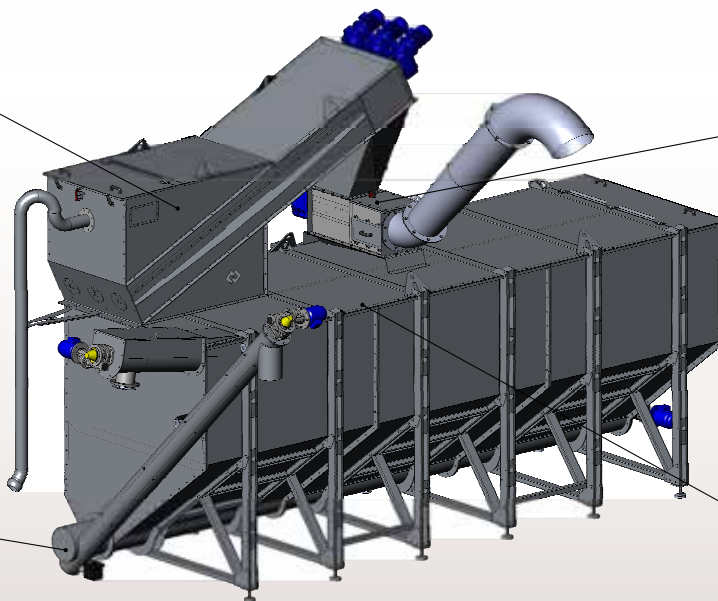

Jagged Conveyor Screw



Extracting screw with variable inclination



Floating Screw System

## Included Accessories

- Blower

- Solenoid Valves

# Application



203001343 April 2018 Rights reserved to modify technical specifications.

This brochure has been edited for distribution in European Union countries



**SAVECO**<sup>™</sup>  
Member of WAMGROUP<sup>®</sup>



[www.saveco-water.com](http://www.saveco-water.com)