

# Waste Water Treatment

## Hydraulic Compactors CHP



22



### Description ▼

Hydraulic Compactors CHP are composed of a compaction zone equipped with a hydraulic ram, a hydraulic gear case, and a compacting pipe.

Screenings fall into the compactor hopper. The hydraulic ram dehydrates the screenings pushing them into the compacting pipe where they are pressed again before being conveyed to the outlet. The liquid from dehydration is drained in the bottom part of the compactor.

### Application ▼



### Benefits ▼

- ✓ Volume reduction of up to 60%;
- ✓ Low running and maintenance costs;
- ✓ Small footprint.



[www.savi-water.com](http://www.savi-water.com)  
[www.wamgroup.com](http://www.wamgroup.com)

# Waste Water Treatment

## Hydraulic Compactors CHP



### Technical Features / Performance ▼

- ▶ 2 sizes
- ▶ From 1.5 up to 3.5 m<sup>3</sup>/h screenings
- ▶ Manufactured from carbon steel hot dip galvanized/ 304 L / 316 L SS
- ▶ Inlet hopper in different sizes (option)
- ▶ Compacting pipe in different lengths and installation angles (option)
- ▶ Control panel (option)

### Overall Dimensions ▼

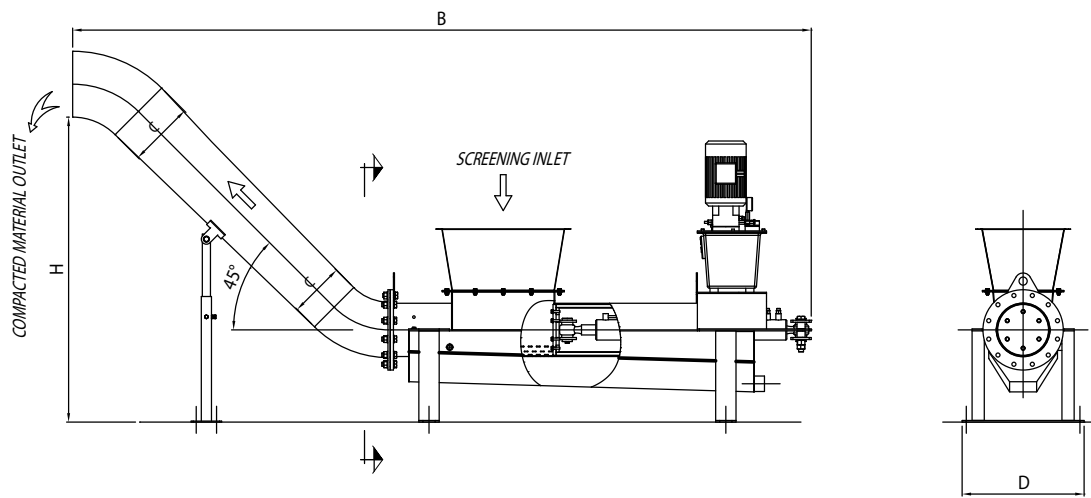

HYDRAULIC COMPACTOR CHP

Technical Features	CHP 200	CHP 250
NOMINAL DIAMETER - mm	DN 200	DN 250
COMPACTION PIPE C - DN	DN 200 / DN 250	DN 250 / DN 300
HYDRAULIC PISTON - mm	70 / 40	80 / 50
PRESSURE - bar	80 / 120	80 / 120
TOTAL LENGTH B - mm	3545	3635
TOTAL WIDTH D - mm	560	600
DISCHARGE HEIGHT H - mm	1500	1500
SCREENINGS INLET - mm	600 X 400	600 X 400
COMPACTION DEGREE - %	60%	60%
FLOW RATE - m <sup>3</sup> /h	1.5	2.5
INSTALLED POWER - kW	2.2	3.0
PROTECTION	IP 55	IP 55

