

MVE 1530/6N-HF-38E

OVERALL DIMENSION

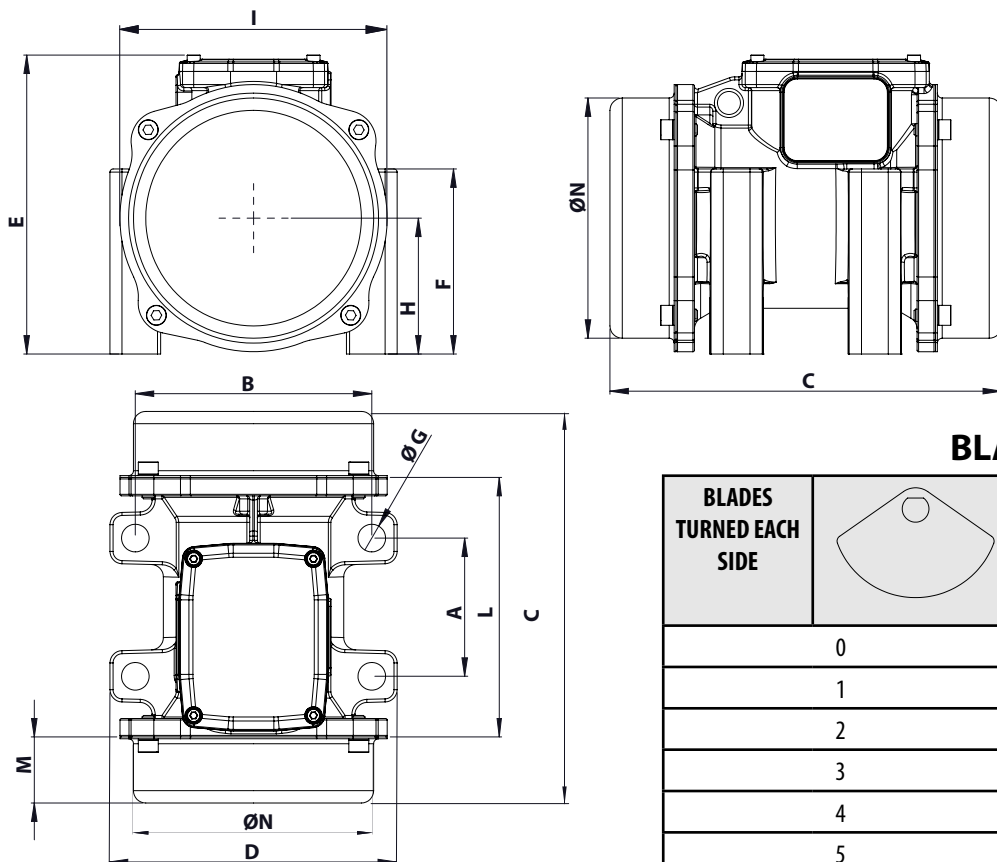
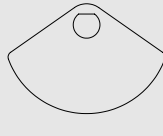

BLADE ADJUSTING

BLADES TURNED EACH SIDE		%Fc	FC (N)	FC (KG)	FC (Lb)
0		100%	13583.57	1384.66	3052.63
1		76%	10373.26	1057.42	2331.18
2		58%	7841.46	799.33	1762.21
3		50%	6792.85	692.44	1526.56
4		58%	7841.73	799.36	1762.27
5		76%	10373.04	1057.39	2331.13

TECHNICAL DATA			
DESIGNATION	VALUE	UNIT	NOTE
Type	MVE 1530/6		
Rated Voltage	42	(V)	+/- 10%
Rated Frequency	200	(Hz)	
Rated Power	1.00	(Kw)	
Rated Current	18	(A)	
Phases	3		
Std. F.C	800	(Kg)	
Vibrations	6000	(Rpm)	
	100	(Hz)	
Max. F.c	1385	(Kg)	
Weight	12	(Kg)	
Protection class	IP66		

CONNITION

EXTENSION CABLE	
≤10m	2.5mm ²
≤20m	4mm ²

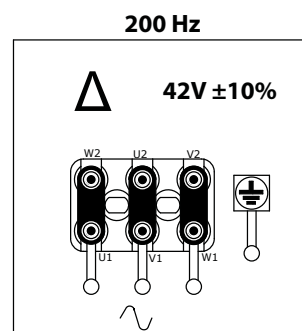

FIXING

FIXING BOLTS			
SCREW	WASHER	NUT	C.TORQUE
M16 (DIN 912,933) - 8.8	M16 - 17,5X30X8 - (DIN 7989)	M16 - 17,5X30X8 - (DIN 934)	210 Nm / 155 FtLb

