



WAM®



1

TECHNICAL CATALOGUE

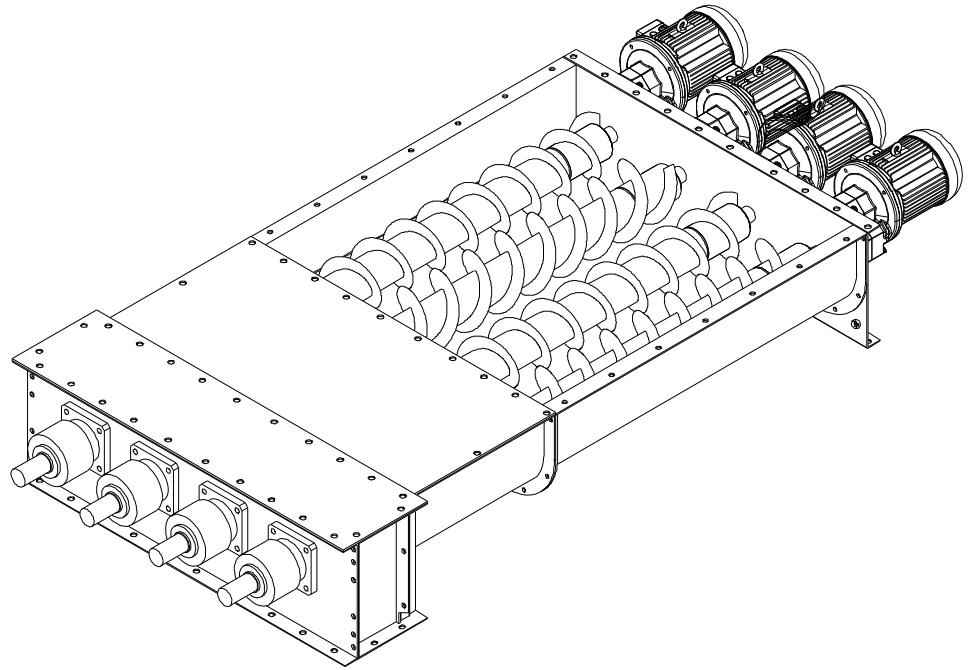

MU

- **LIVE BIN BOTTOMS**
TECHNICAL CATALOGUE
- **SCHNECKENAISTRAGEBÖDEN**
TECHNISCHER KATALOG
- **EXTRACTEURS MULTIPLES À VIS**
CATALOGUE TECHNIQUE
- **ESTRATTORI MULTIPLI A COCLEA**
CATALOGO TECNICO

All rights reserved © WAMGROUP

CATALOGUE No. **WA.01520 T.**

ISSUE
A4

CIRCULATION
100

LATEST UPDATE
09.10



WAM®

All the products described in this catalogue are manufactured according to **WAM® S.p.A. Quality System procedures.**

The Company's Quality System, certified in July 1994 according to International Standards **UNI EN ISO 9002-94** and extended to **UNI EN ISO 9001-2000** in October, 2002, ensures that the entire production process, starting from the processing of the order to the technical service after delivery, is carried out in a controlled manner that guarantees the quality standard of the product.

*Alle in diesem Katalog beschriebenen Erzeugnisse werden in Konformität mit dem **Qualitätssystem der WAM® S.p.A. hergestellt.***

*Das im Juli 1994 zertifizierte Qualitätssystem entspricht der Norm **UNI EN ISO 9002-94** (im Oktober 2002 auf **UNI EN ISO 9001-2000** erweitert) und gewährleistet dem Kunden eine strenge Qualitätskontrolle in jeder Phase des Produktionsprozesses bis hin zum Kundendienst nach Auslieferung der Ware.*

Tous les produits décrits dans ce catalogue ont été réalisés selon les modalités opérationnelles définies **Système de Qualité de WAM® S.p.A.**

Le système de Qualité de l'entreprise, certifié au mois de juillet 1994 en conformité aux Normes Internationales **UNI EN ISO 9002-94** et successivement étendu à **UNI EN ISO 9001-2000** au mois de octobre 2002, est en mesure d'assurer que le procédé entier de production, à partir de la formulation de la commande jusqu'au service technique après la livraison, soit effectué de manière contrôlée et appropriée afin de garantir le standard de qualité du produit.

*Tutti i prodotti descritti in questo catalogo sono stati realizzati secondo modalità operative definite **Sistema Qualità di WAM® S.p.A.***

*Il Sistema Qualità aziendale, certificato dal luglio 1994 in conformità alle Normative Internazionali **UNI EN ISO 9002-94** e successivamente esteso alle Normative Internazionali **UNI EN ISO 9001-2000** nell'ottobre 2002, è in grado di assicurare che l'intero processo produttivo, dalla formulazione dell'ordine fino all'assistenza tecnica successiva alla consegna, venga effettuato in modo controllato ed adeguato a garantire lo standard qualitativo del prodotto.*



**This publication cancels and replaces any previous edition and revision.
We reserve the right to implement modifications without notice.
This catalogue cannot be reproduced, even partially, without prior consent.**

***Diese Veröffentlichung annulliert und ersetzt jeder hergehende Edition oder Revision.
WAM® behält sich das Recht vor, Änderungen ohne vorherige Informationen durchzuführen.***

**Cette publication annule et remplace toutes les autres précédentes.
Nous nous réservons le droit d'apporter toutes modifications à nos produits.
La reproduction et la publication partielle ou totale de ce catalogue est interdite sans notre autorisation.**

***Questa pubblicazione annulla e sostituisce ogni precedente edizione o revisione.
Ci riserviamo il diritto di apportare modifiche senza preavviso.
E' vietata la riproduzione anche parziale senza autorizzazione.***

1 TECHNICAL CATALOGUE	1 TECHNISCHER KATALOG
CODE INDEX.....	CODES.....T .01
INTRODUCTION.....	EINFÜHRUNG.....02
STANDARD SUPPLY.....	STANDARD-LIEFERUMFANG.....03
OVERALL DIMENSION AN-TYPE.....	EINBAUMASSE TYP AN.....04
ACCESSORIES.....	ZUBEHÖR.....05
MU_P - MU_E STRUCTURAL COMPONENTS.....	STAHLBAUTEILE MU_P - MU_E.....06
MU_P - MU_E MECHANICAL COMPONENTS.....	MECHANISCHE KOMponentEN MU_P - MU_E.....07
DIRECT DRIVE (S-TYPE GEAR REDUCER).....	DIREKTANTRIEB (S-GETRIEBE).....08
DRIVE UNIT LAYOUT.....	ANTRIEBSANORDNUNG.....09→.11
FINISHING.....	FINISH.....12
COLOURS.....	FARBÖNE.....13
MU TYPE MODULAR CODE KEY.....	SUCHCODESCHLÜSSEL TYP MU.....14→.16
INQUIRY FORM.....	ANFRAGEFORMULAR.....17→.20
MEDIUM-HEAVY DUTY TROG.....	TROG MITTELSCHWER.....21
EXTRA-HEAVY DUTY TROG.....	TROG SCHWER.....22
TROUGH FLANGE DRILLING.....	TROGFLANSHLOCHBILD.....23
END PLATE XP - TYPE.....	ENDSCHILD XP.....24
END PLATE.....	ENDSCHILD.....25
DRILLING SCHEME.....	BOHRPLAN.....26→.27
SCREW DIRECTION AND ROTATION.....	SCHRAUBENRICHTUNG UND DREHSINN.....28
P SCREW.....	SCHNECKENWENDEL P.....29
E SCREW.....	SCHNECKENWENDEL E.....30
XJQ - TYPE COVER SUPPORT BRACKET.....	ABDECKUNGSAUFLAGEBÜGEL TYP XJQ.....31
TROUGH COVER.....	TROGABDECKUNG.....32
COVER LOCK.....	ABDECKUNGSVERSCHLUSS.....33
END BEARING ASSEMBLY TYPE - XSP.....	ENDLAGEREINHEIT XSP.....34
END BEARING ASSEMBLY TYPE - XSR.....	ENDLAGEREINHEIT XSR.....35
SHAFT SEALING TYPE - XUC.....	WELLENABDICHTUNG TYP XUC.....36
SHAFT COUPLINGS XAA and XAC.....	WELLENVERBINDUNGEN XAA und XAC.....37
SHAFT COUPLING XAV.....	WELLENVERBINDUNG XAV.....38
GEAR REDUCER - TYPE S 21-23-25-27.....	GETRIEBE TYP S 21-23-25-27.....39→.40
MOTOR MT.....	MOTOR MT.....41→.42
OPTIONS - XAL SPLINED AND BOLTED SHAFT COUPLING.....	VARIANTEN - VIELKEILWELLENVERBINDUNG VERSTIFTET XAL.....43
OPTIONS - SHAFT COUPLINGS XAQ-XAT.....	VARIANTEN - WELLENVERBINDUNG XAQ-XAT.....44
OPTIONS - COUPLING TRANSMISSION ("S"-TYPE GEAR REDUCER).....	VARIANTEN - KUPPLUNG (GETRIEBE TYP "S").....45
OPTIONS - CHAIN TRANSMISSION ("S"-TYPE GEAR REDUCER).....	VARIANTEN - KETTENTRIEB (GETRIEBE TYP "S").....46
OPTIONS - SCREW WITH BLADES.....	VARIANTEN - PADDELWENDEL.....47
OPTIONS - XSQ END BEARING ASSEMBLY.....	VARIANTEN - ENDLAGEREINHEIT TYP XSQ.....48
OPTIONS - XSS END BEARING ASSEMBLY.....	VARIANTEN - ENDLAGEREINHEIT TYP XSS.....49
ACCESSORIES - SQUARE INLET.....	ZUBEHÖR - EINLAUF.....50
ACCESSORIES - XFBA - TYPE OVERFLOW HATCH FLAP.....	ZUBEHÖR - ÜBERLAUFKLAPPE TYP XFBA.....51
ACCESSORIES - FLOW STOPPING DIAPHRAGM XJE.....	ZUBEHÖR - DURCHFLUSSSPERRE XJE.....52
ACCESSORIES - XKX-TYPE FINGER MESH BENEATH HATCH FLAP.....	ZUBEHÖR - SCHUTZGITTER TIP XKX UNTER ÜBERLAUFKLAPPE.....53
ACCESSORIES - TUBULAR INSERT XJG.....	ZUBEHÖR - VERDRÄNGUNGSELEMENT XJG.....54
ACCESSORIES - MEMBRANE HATCH.....	ZUBEHÖR - MEMBRANKLAPPE.....55
ACCESSORIES - ROTATIONAL INDICATOR BRACKET XVA.....	ZUBEHÖR - SOCKEL FÜR ROTATIONSMELDER XVA.....56
ADDITIONAL INTERNAL SEAL XUJ.....	ZUSÄTZLICHE INNENDICHTUNG XUJ.....57
ACCESSORIES - TROUGH FOOT TYPE XJS.....	ZUBEHÖR - TROGFUSS TYP XJS.....58
ACCESSORIES - REINFORCEMENT RINGS.....	ZUBEHÖR - VERSTÄRKUNGSRINGE.....59
OPTIONS - QUICK REMOVABLE SCREW.....	VARIANTEN - SCHNELLE HERAUSZIEHBARE WENDEL.....60
TROUGH CONFIGURATION Ø 100 - 250.....	TROGKONFIGURATION Ø 100 - 250.....61
SHIPPING DATA.....	KOLLIDATEN.....62
WEIGHTS MU_P.....	GEWICHTE MU_P.....63
WEIGHTS MU_E AN.....	GEWICHTE MU_E AN.....64

1	CATALOGUE TECHNIQUE	1	CATALOGO TECNICO	
	CODES ET SIGLES.....		CODICI E SIGLE.....	T. 01
	INTRODUCTION.....		INTRODUZIONE.....	02
	COMPOSITION STANDARD.....		FORNITURA STANDARD.....	03
	ENCOMBREMENT TYPE AN.....		INGOMBRO TIPO AN.....	04
	ACCESSOIRES.....		ACCESSORI.....	05
	COMPOSANTS STRUCTURE MU_P - MU_E.....		COMPONENTI COMPONENTI CARPENTERIA MU_P - MU_E.....	06
	COMPOSANTS MECANIKES MU_P - MU_E.....		COMPONENTI MECCANICA MU_P - MU_E.....	07
	ENTRAINEMENT DIRECTE (REDUCTEUR TYPE "S").....		MOTORIZZAZIONE DIRETTA (TESTATA MOTRICE TIPO "S").....	08
	POSITIONS DES MOTORISATIONS.....		DISPOSIZIONE MOTORIZZAZIONI.....	09 → 11
	FINITION.....		FINITURA.....	12
	TONALITES.....		TONALITÀ.....	13
	CODE MODULAIRE TYP MU.....		CHIAVE SIGLA MODULARE TIPO MU.....	14 → 16
	FICHE DE DEMANDE.....		MODULO RICHIESTA.....	17 → 20
	AUGE SERVICE LOURD.....		TRUOGOLO PESANTE.....	21
	AUGE EXTRA LOURD.....		TRUOGOLO EXTRAPESANTE.....	22
	PERÇAGE BRIDE AUGE.....		FORATURA FLANGIA TRUOGOLO.....	23
	FLASQUE COTE XP.....		PORTASUPPORTO XP.....	24
	FLASQUE.....		PORTASUPPORTO.....	25
	SCHÉMA DE PERÇAGE.....		SCHEMA DI FORATURA.....	26 → 27
	SENS DE L'HELICE ET SENS DE ROTATION.....		SENSO DELL'ELICA E VERSO DI ROTAZIONE.....	28
	SPIRE P.....		SPIRA P.....	29
	SPIRE E.....		SPIRA E.....	30
	SUPPORT CAPOT XJQ.....		SOTTOCOPERCHIO XJQ.....	31
	CAPOTAGE.....		COPERCHIO.....	32
	FERMETURE CAPOTAGE.....		CHIUSURA COPERCHIO.....	33
	SUPPORT PALIER D'EXTREMITE TYPE XSP.....		SUPPORTO D'ESTREMITÀ XSP.....	34
	SUPPORT PALIER D'EXTREMITE TYPE XSR.....		SUPPORTO D'ESTREMITÀ XSR.....	35
	ETANCHEITE TYP XUC.....		TENUTA XUC.....	36
	ACCOUPEMENTS XAA et XAC.....		ACCOPIAMENTI XAA e XAC.....	37
	ACCOUPEMENT XAV.....		ACCOPIAMENTO XAV.....	38
	REDUCTEUR TYPE S 21-23-25-27.....		TESTATA MOTRICE S 21-23-25-27.....	39 → 40
	MOTEUR MT.....		MOTORE MT.....	41 → 42
	OPTIONS- ACCOUPLEMET CANNELE ET DEFONCE XAL.....		OPZIONI - ACCOPIAMENTO CALETTATO SPINATO XAL.....	43
	OPTIONS- ACCOUPLEMETS XAQ-XAT.....		OPZIONI - ACCOPIAMENTI XAQ-XAT.....	44
	OPTIONS - ENTRAINEM. AV.ACCOUPLE.DEMI-ELASTIQUE (RED.TYPE "S").....		OPZIONI - TRASMISSIONE CON GIUNTO (TEST.MOTR.TIPO "S").....	45
	OPTIONS - ENTRAINEMENT PAR CHAINE (REDUCTEUR TYPE "S").....		OPZIONI - TRASMISSIONE A CATENA (TEST.MOTR.TIPO "S").....	46
	OPTIONS - SPIRE A PALETTES.....		OPZIONI - ELICA A PALETTE.....	47
	OPTIONS - SUPPORT PALIER D'EXTREMITE TYPE XSQ.....		OPZIONI - SUPPORTO D'ESTREMITÀ XSQ.....	48
	OPTIONS - SUPPORT PALIER D'EXTREMITE TYPE XSS.....		OPZIONI - SUPPORTO D'ESTREMITÀ XSS.....	49
	ACCESSOIRES - BOUCHE D'ENTREE.....		ACCESSORI - BOCCA CARICO.....	50
	ACCESSOIRES - CAPOT MOBILE XFBA.....		ACCESSORI - PORTELLO XFBA.....	51
	ACCESSOIRES - DIAPHRAGME ARRET DE FLUX XJE.....		ACCESSORI - DIAFRAMMA FERMAFLUSSO XJE.....	52
	ACCESSOIRES - GRILLE SOUS CAPOT MOBILE XKX.....		ACCESSORI - RETE SOTTOPORTELLO XKX.....	53
	ACCESSOIRES - INSERT TUBULAIRE XJG.....		ACCESSORI - INSERTO TUBOLARE XJG.....	54
	ACCESSOIRES - TRAPPE A MEMBRANE.....		ACCESSORI - PORTELLO A MEMBRANA.....	55
	ACCESSOIRES - BASE POUR AVERTISSEUR DE ROTATION XVA.....		ACCESSORI - BASETTA PER SEGNALETORE DI ROTAZIONE XVA.....	56
	ÉTANCHÉITÉ INTERNE ADDITIONNELLE.....		TENUTA ADDIZIONALE INTERNA XUJ.....	57
	ACCESSOIRES - SEMELLE SUPPORT XJS.....		ACCESSORI - SELLA XJS.....	58
	ACCESSOIRES - ANNEAUX DE RENFORT.....		ACCESSORI - ANELLI DI RINFORZO.....	59
	OPTIONS - SPIRES RAPIDEMENTEXTRACTIBLES.....		OPZIONI - RAPIDA ESTRAIBILITÀ SPIRE.....	60
	DISPOSITION CONSTRUCTIVE.....		DISPOSIZIONE TRUOGOLI.....	61
	COLISAGE.....		INGOMBRI SPEDIZIONE.....	62
	POIDS MU_P.....		PESI MU_P.....	63
	POIDS MU_E AN.....		PESI MU_E AN.....	64

MUP	Heavy-duty live bin bottom	Austragsschneckenboden mittelschwer	Extracteur multiple lourd	Estrattore multiplo pesante
MUE	Extra-heavy-duty live bin bottom	Austragsschneckenboden schwer	Extracteur multiple extra lourd	Estrattore multiplo extra pesante
S21	Gear reducer	Getriebe	Réducteur	Testata motrice
S23	Gear reducer	Getriebe	Réducteur	Testata motrice
S25	Gear reducer	Getriebe	Réducteur	Testata motrice
S27	Gear reducer	Getriebe	Réducteur	Testata motrice
XC	Trough	Trog	Auge	Truogolo
XP	End plate	Endschild	Flasque	Portasupporto
XE	Screw	Wendel	Helice	Elica
XF	Trough cover	Trogabdeckung	Couvercle	Coperchio
XKH	Cover lock	Abdeckungsverschluß	Fermeture capotage	Chiusura coperchio
XSP	End bearing assembly	Endlagereinheit	Support palier d'extrémité	Supporto d'estremità
XSR	End bearing assembly	Endlagereinheit	Support palier d'extrémité	Supporto d'estremità
XAA	Shaft coupling	Wellenverbindung	Accouplement arbre	Accoppiamento albero
XAC	Shaft coupling	Wellenverbindung	Accouplement arbre	Accoppiamento albero
XAV	Shaft coupling	Wellenverbindung	Accouplement arbre	Accoppiamento albero
XUC	Shaft sealing	Wellenabdichtung	Etanchéité	Tenuta
MT	Electric motor	Elektromotor	Moteur électrique	Motore
XH	Transmission	Kraftübertragung	Entraînement	Trasmissione
XBQ	Square spout	Quadratischer Stutzen	Bouche carrée	Bocca quadra
XBV	Rectangular spout	Rechteckstutzen	Bouche rectangulaire	Bocca rettangolare
XBR	Rectangular spout	Rechteckstutzen	Bouche rectangulaire	Bocca rettangolare
XBW	Flush outlet	Frontalauslauf	Bouche d'extrémité	Bocca d'estremità
XFBA	Overflow hatch flap	Überlaufklappe	Capot mobile	Portello apribile
XKX	Finger mesh overflow hatch	Schutzgitter unter Überlaufklappe	Grille sous capot	Rete sottoportello
XKY	Membrane hatch	Membranklappe	Trappe à membrane	Portello a membrana
XJQ	Cover support bracket	Abdeckungsauflagebügel	Support capot	Sottocoperchio
XJV	Separating diaphragm	Trennwehr	Diaphragme de division	Diaframma divisorio
XJE	Flow stopping diaphragm	Durchflußsperre	Diaphragme arrêt de flux	Diaframma fermaflusso
XJG	Tubular insert	Verdrängungselement	Insert tubulaire	Inserto tubolare
XKZ	Rotational indicator bracket	Halterung für Drehzahlwächter	Base avertisseur de rotation	Basetta segnalatore di rotazione
XJS	Trough foot	Trogfuß	Semelle support	Sella
XKM	Screw clamp	Schraubzwingenverschluß	Pince à vis	Morsetto a vite

MU_1P = Heavy-duty live bin bottom, complete with gear motor.
MU_1E = Extra-heavy-duty live bin bottom, complete with gear motor.
MU_1PS = same as **MU_1P** but beyond standard length without intermediate hanger bearings.
MU_1ES = same as **MU_1E** but beyond standard length without intermediate hanger bearings.
MU_1P_AN = same as **MU_1P**, but with bare shaft only.
MU_1E_AN = same as **MU_1E**, but with bare shaft only.
MU_1PSAN = same as **MU_1PS**, but with bare shaft only.
MU_1ESAN = same as **MU_1ES**, but with bare shaft only.

MU_1P = Austragschneckenboden in mittelschwerer Ausführung inkl. Antriebseinheit.
MU_1E = Austragschneckenboden in schwerer Ausführung inkl. Antriebseinheit.
MU_1PS = wie **MU_1P**, jedoch Überlänge ohne Zwischenlager.
MU_1ES = wie **MU_1E**, jedoch Überlänge ohne Zwischenlager.
MU_1P_AN = wie **MU_1P**, jedoch mit freiem Wellenende ohne Antrieb.
MU_1E_AN = wie **MU_1E**, jedoch mit freiem Wellenende ohne Antrieb.
MU_1PSAN = wie **MU_1PS**, jedoch mit freiem Wellenende ohne Antrieb.
MU_1ESAN = wie **MU_1ES**, jedoch mit freiem Wellenende ohne Antrieb.

MU_1P = extracteurs multiples en auge pour service lourd, motorisation comprise.
MU_1E = extracteurs multiples en auge pour service extra-lourd, motorisation comprise.
MU_1PS = comme **MU_1P** mais avec longueur majorée sans paliers intermédiaires.
MU_1ES = comme **MU_1E** mais avec longueur majorée sans paliers intermédiaires.
MU_1P_AN = comme **MU_1P**, mais à arbre nu.
MU_1E_AN = comme **MU_1E**, mais à arbre nu.
MU_1PSAN = comme **MU_1PS**, mais à arbre nu.
MU_1ESAN = comme **MU_1ES**, mais à arbre nu.

MU_1P = estrattori multipli a canale per servizio pesante, complete di testata motrice.
MU_1E = estrattori multipli a canale per servizio extrapesante, complete di testata motrice.
MU_1PS = come **MU_1P** senza supporti intermedi, con lunghezza maggiorata.
MU_1ES = come **MU_1E** senza supporti intermedi, con lunghezza maggiorata.
MU_1P_AN = come **MU_1P**, ma ad albero nudo.
MU_1E_AN = come **MU_1E**, ma ad albero nudo.
MU_1PSAN = come **MU_1PS**, ma ad albero nudo.
MU_1ESAN = come **MU_1ES**, ma ad albero nudo.

This equipment is NOT suitable for handling of foodstuff. The screw conveyor must not be started before the screw conveyor itself, as well as the plant it is going to be installed in, have been declared in conformity with the European Directive 14/06/1982 (89/392/EEC). It is the plant designer's / plant fitter's responsibility to design and install all necessary protection in order to avoid that breaking and / or yielding of the equipment or of parts of it might damage people and / or parts of the plant (e.g. adequate protection against falling down of the motor etc.). For dangerous materials, i.e. those that must not get in contact with the human body or be inhaled, for flammable, explosive and bacteriologically dangerous materials the plant manufacturer or fitter must provide for the required safety devices and measures.

Die in dieser Dokumentation genannten Schneckenförderer sind NICHT zum Handling von Nahrungsmitteln geeignet. Die Schnecke darf nicht in Betrieb genommen werden, bevor sowohl sie selbst, als auch die Anlage, in die sie eingebaut wird, mit den Vorschriften der Direktive 14/06/1982 (89/392/ECC) für konform erklärt wurde. Es liegt in der Verantwortung des Anlagenplaners bzw. -aufstellers, alle notwendigen Schutzvorrichtungen vorzusehen, welche es verhindern, daß durch einen Geräte- oder Teiledefekt Personen- und/oder Sachschäden verursacht werden (z.B. geeigneter Schutz gegen das Herunterfallen des Motors etc.). Für Gefahrenprodukte, bzw. solche, die nicht mit dem menschlichen Körper in Kontakt geraten oder eingeatmet werden dürfen, für leicht entzündbare, explosive sowie bakteriologisch gefährliche Medien muß der Anlagenbauer bzw. -errichter die für die Sicherheit erforderlichen Vorrichtungen vorsehen und Maßnahmen treffen.

Ces machines NE sont PAS indiquées au transport de produits alimentaires. En outre, il est interdit de les mettre en fonction avant que la machine / l'installation dans laquelle elles doivent être montées a été déclarée conforme aux dispositions de la Directive 14/06/1982 (89/392/ECC). Dans ce cadre il est la responsabilité du constructeur de l'installation ou de l'installateur de projeter et d'installer tout équipement de protection nécessaire afin d'éviter que des ruptures et / ou des parties d'elle puissent causer de dégâts à des personnes et / ou des choses (par ex.: des protections appropriées contre la chute du moteur etc.). Pour des produits dangereux, nuisibles au contact et/ou à l'inhalation, inflammables, explosifs et dangereux du point de vue bactériologique et/ou viral, le constructeur de l'installation ou l'installateur devront prévoir des dispositifs appropriés au besoin.

Queste macchine sono in acciaio al carbonio e NON sono idonee al trasporto di prodotti alimentari. E' inoltre vietato metterle in funzione prima che la macchina/impianto nel quale devono essere installate sia dichiarato conforme alle disposizioni della direttiva 14/06/1982 (89/392/EEC). In quest'ambito è cura dell'installista / installatore predisporre ed installare tutti gli accorgimenti / protezioni al fine di evitare danni a cose o persone in caso di rotture e conseguente caduta di pezzi della macchina (ad es.: rottura del motore). Per prodotti pericolosi, nocivi al contatto e/o all'inhalazione, infiammabili, esplosivi e pericolosi dal punto di vista batteriologico e/o virale, l'installista e/o l'installatore, dovranno prevedere idonei dispositivi all'uopo.

Geometry and shape of MU Live Bin Bottoms are in conformity with a material discharging device. MU Live Bin Bottoms are not sized to perform structural support functions of a bin, hopper or silo bottom. It is the plant fitter's responsibility to support the silo, hopper or bin in a correct fashion. **MU Live Bin Bottoms have to be supported at both ends and in the intermediate section. The number of supports in the intermediate section has to be defined by the plant fitter depending on the quantity of material weighing on the MU Live Bin Bottom.**

Geometrie und Form der MU Schneckenaustragsböden entsprechen allein der Anforderung, ein Schüttgut auszutragen. MU Schneckenaustragsböden sind nicht dafür ausgelegt, eine Abstützfunktion des jeweiligen Trichters, Behälters oder Silos zu erfüllen. Es liegt in der Verantwortung des Anlagenaufstellers, den Trichter, Behälter oder Silo in angemessener Weise abzustützen. **MU Schneckenaustragsböden müssen sowohl an beiden Enden, als auch im mittleren Abschnitt abgestützt werden. Die Anzahl der Abstützungen im mittleren Abschnitt ist vom Anlagenaufsteller festzulegen und hängt in jedem Fall von der Materialmenge ab, welche auf dem MU Schneckenaustragsboden lastet.**

La géométrie et la forme des extracteurs multiples à vis sont dimensionnés comme système pour l'extraction du produit. Les MU ne sont donc pas dimensionnés pour mener la fonction structurale de fond d'une trémie, ou d'un silo ou de n'importe quel autre type de récipient. Il est la responsabilité de l'installateur de supporter l'extracteur MU correctement. **L'extracteur MU doit être supporté aux deux extrémités et dans la partie intermédiaire. Le nombre de supports dans la partie intermédiaire doit être défini par l'installateur en fonction du poids du matériau gravant sur l'extracteur-même.**

La geometria e la forma dell'MU sono dimensionati come sistema per l'estrazione del prodotto. L'MU quindi non è dimensionato per svolgere la funzione strutturale di fondo di una tramoggia, di un silo o di qualunque altro contenitore. Sarà cura dell'installatore supportarlo correttamente. **L'estrattore MU deve essere supportato alle due estremità e nel tratto intermedio. Il numero di supporti nel tratto intermedio dovrà essere definito dall'installatore in funzione del peso del materiale gravante sull'estrattore stesso.**

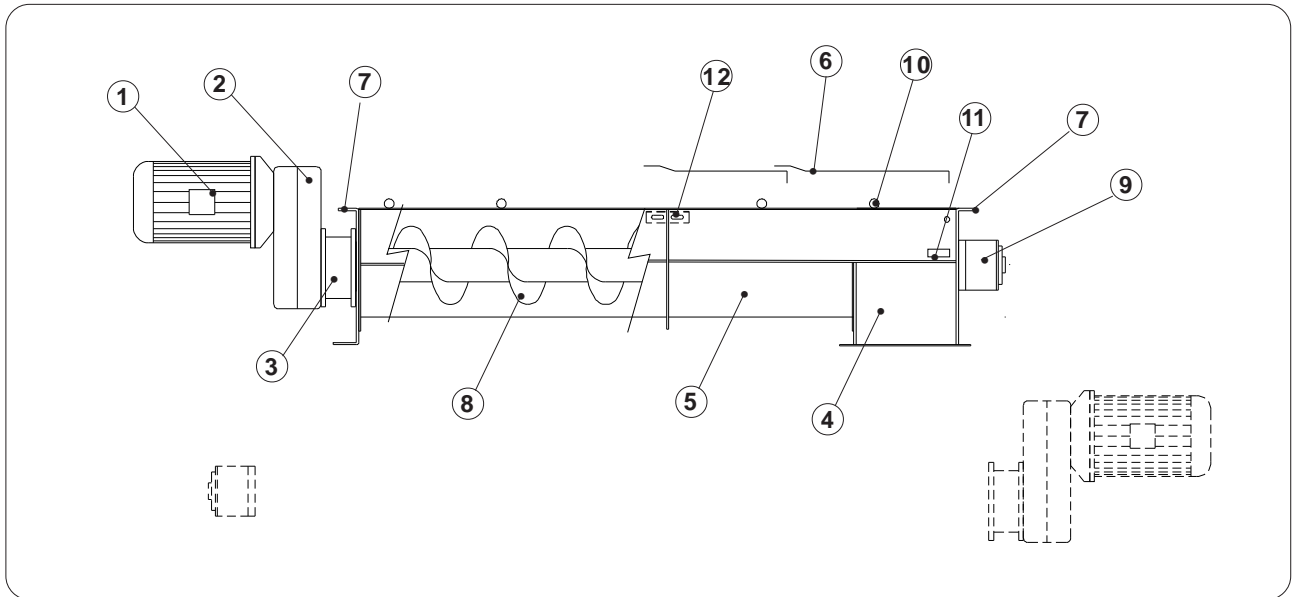

1	ELECTRIC MOTOR	ELEKTROMOTOR	MOTEUR ELECTRIQUE	MOTORE ELETTRICO	MT
2	GEAR REDUCER	GETRIEBE	REDUCTEUR	TESTATA MOTRICE	S
3	SHAFT SEALING	WELLENABDICHTUNG	ETANCHEITE	TENUTA	XUC
4	OUTLET	AUSLAUF	BOUCHE DECHARGE	BOCCA SCARICO	XBQ
5	TROUGH	TROG	AUGE	TRUOGOLO	XC_
6	COVER	TROGABDECKUNG	COUVERCLE	COPERCHIO	XFC
7	END PLATE	ENDSCHILD	REHAUSSE	PORTA SUPPORTO	XP_
8	SCREW	SCHNECKENWENDEL	SPIRE	SPIRA	XE-
9	END BEARING ASSEMBLY	ENDLAGEREINHEIT	SUPPORT PALIER D'EXTREMITÉ	SUPPORTO ESTREMITA'	XS_
10	LIFTING EYE	KRANÖSE	OUILLET	GOLFARO	-
11	SERIAL NUMBER	PRODUKTIONSNUMMER	NUMERO DE MATRICOLA	NUMERO MATRICOLA	-
12	COVER SUPPORT BRACKETS	ABDECKUNGSAUFLAGEBÜGEL	SUPPORT DE CAPOTS	SOTTOCOPERCHI	XJQ

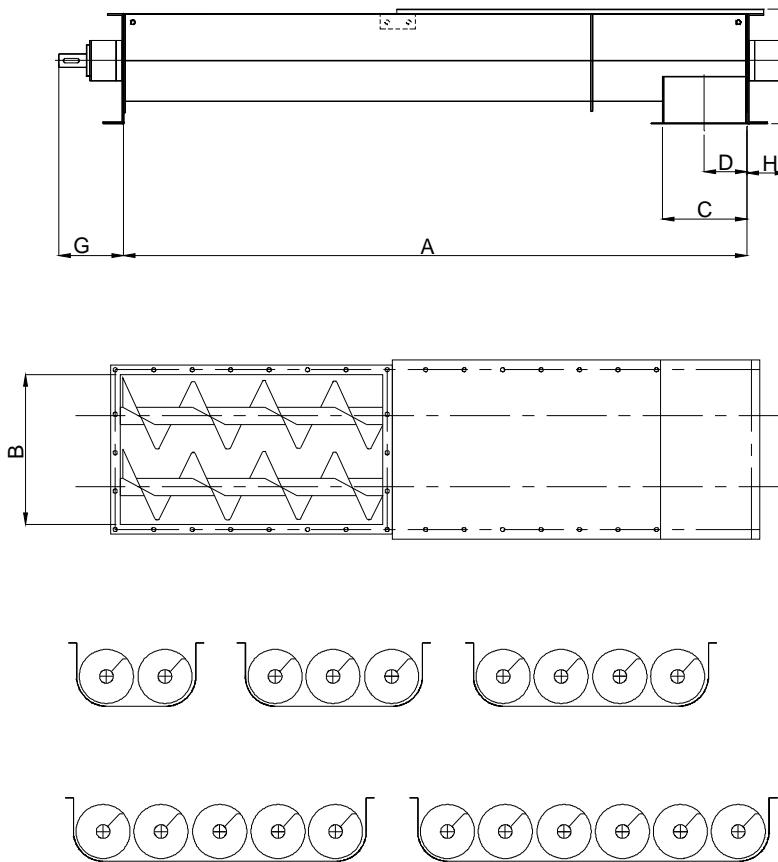

Ø	A (m)	B (mm)					C (mm)	D (mm)	E (mm)	F (mm)	G (mm)	H (mm)
		2 SCREWS WENDELN HELICES ELICHE	3 SCREWS WENDELN HELICES ELICHE	4 SCREWS WENDELN HELICES ELICHE	5 SCREWS WENDELN HELICES ELICHE	6 SCREWS WENDELN HELICES ELICHE						
150	1.5 - 2 - 2.5 - 3	340	505	670	835	1000	172	86	145	115	182	124
200	1.5 - 2 - 2.5 - 3	445	665	885	1105	1325	222	111	185	135	182	124
250	1.5 - 2 - 2.5 - 3	545	815	1085	1355	1625	262	131	215	160	225	143
300	1.5 - 2 - 2.5 - 3 - 3.5 - 4	645	965	1285	1605	1925	315	157.5	245	195	233	151
350	2 - 2.5 - 3 - 3.5 - 4	755	1135	1515	1895	2275	370	185	275	235	233	151
400	2.5 - 3 - 3.5	850	1275	1700	2125	2550	417	208.5	305	270	267	162
500	2.5 - 3	1045	1565	2085	2605	3125	512	256	380	340	310	180
600	2.5 - 3 - 3.5 - 4	1245	1865	2485	3105	3725	607	303.5	465	420	310	180

Contact the Manufacturer - *Beim Hersteller nachfragen*
 Consulter le Fabricant - *Consultare il Costruttore*

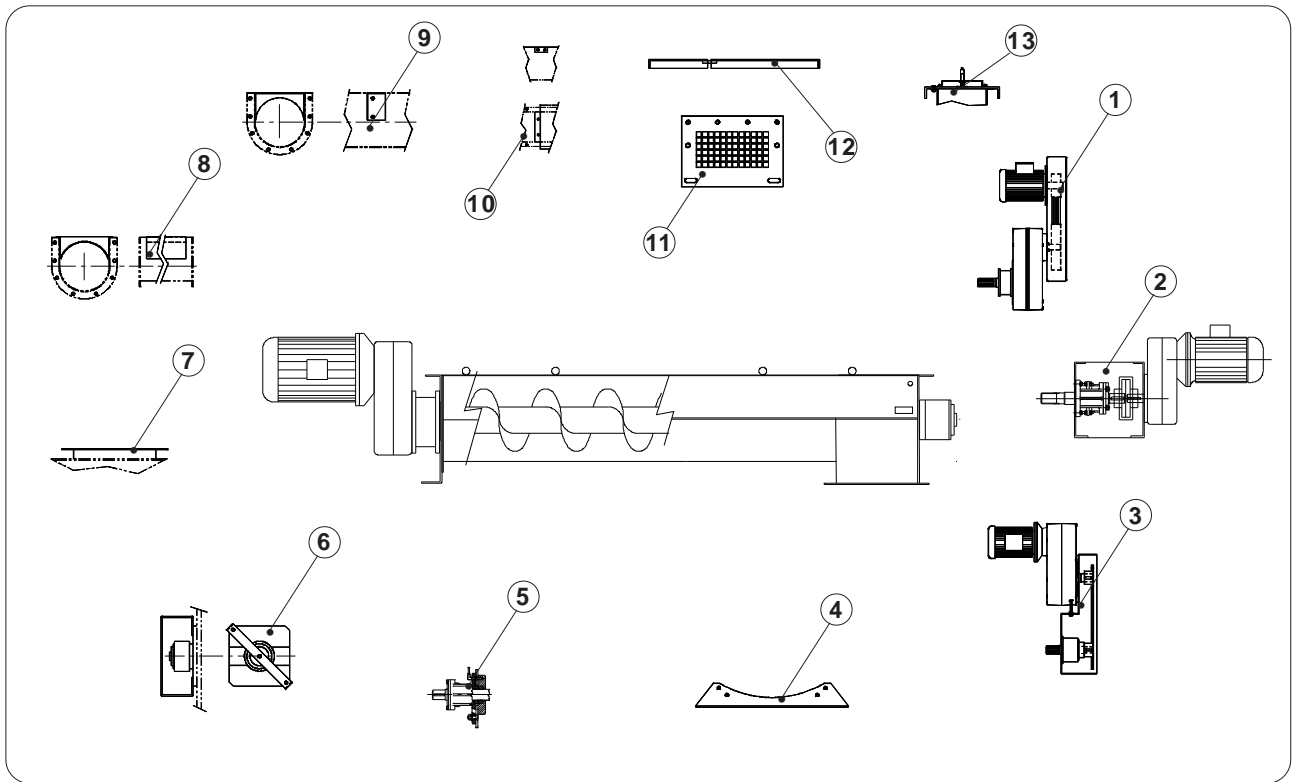

Item Pos.	DESCRIPTION	BENENNUNG	DESIGNATION	DESCRIZIONE	Code
1	Belt transmission	Riementrieb	Entraînement par courroies	Trasmissione a cinghia	
2	Coupling transmission	Kupplung	Entraînement par accouplement	Trasmissione con giunto	
3	Chain transmission	Kettentrieb	Entraînement par chaîne	Trasmissione a catena	
4	Trough foot	Trogfuß	Semelle support	Sella	XJS
5	Special shaft seals	Spezial-Wellenabdichtungen	Etanchéités spéciales	Tenute speciali	
6	Rotational indicator bracket	Sokel für Rotationsmelder	Base pour avertisseur de rotation	Basetta per segnalatore di rotazione	XKZ
7	Inlet	Einlauf	Bouche d'entrée	Bocca carico	XB-
8	Tubular insert	Verdrängungselement	Insert tubulaire	Inserto tubolare	XJG
9	Flow stopping diaphragm	Durchflußsperre	Diaphragme arrêt de flux	Diaframma fermaflusso	XYE
10	Cover support bracket	Abdeckung-Auflagebügel	Support capot	Sottocoperchio	XJQ
11	Finger mesh overflow hatch	Schutzgitter unter Überlauklappe	Grille sous capot	Rete sotto portello	XKX
12	Overflow hatch flap	Überlauklappe	Capot mobile	Portello	XFBA
13	Membrane hatch	Membranklappe	Trappe à membrane	Portello a membrana	XKY

MU_P

Ø	Trough Trog Auge Truogolo	Screw / Schneckenwendel Spire / Spira				Centre pipe - Innenrohr Tube interieur - Tubo interno		Inlet Einlauf Entrée Carico	Outlet Auslauf Decharge Scarico	Cover Abdeckung Capot Coperchio	Cover lock Befest. Abdeckung Fixation capot Fissaggio coperchio
		Ø e (mm)	Ø i (mm)	S (mm)	Pitch Steig. Pas Passo	Ø	S				
150	3	150	60	3	Variable Variabel Variabile Variable	60	7	on request auf Wunsch sur demande su richiesta	XBQ015...	XFCC	Bolts Geschraubt Boulonné Bulloni
200	3	200	60	4		60	7		XBQ020...	XFCC	
250	3	250	60	4		60	7		XBQ025...	XFCC	
300	4	300	114	4		114	7		XBQ030...	XFCC	
350	4	350	114	4		114	7		XBQ035...	XFCC	
400	4	400	114	5		114	7		XBQ040...	XFCC	
500	4	500	114	5		114	7		XBQ050...	XFCC	
600	4	600	168	6		168	7		XBQ060...	XFCC	

Contact the Manufacturer - *Beim Hersteller nachfragen*
 Consulter le Fabricant - *Consultare il Costruttore*

MU_E

Ø	Trough Trog Auge Truogolo	Screw / Schneckenwendel Spire / Spira				Centre pipe - Innenrohr Tube interieur - Tubo interno		Inlet Einlauf Entrée Carico	Outlet Auslauf Decharge Scarico	Cover Abdeckung Capot Coperchio	Cover lock Befest. Abdeckung Fixation capot Fissaggio coperchio
		Ø e (mm)	Ø i (mm)	S (mm)	Pitch Steig. Pas Passo	Ø	S				
150	4	150	60	4	Variable Variabel Variabile Variable	60	7	on request auf Wunsch sur demande su richiesta	XBQ015...	XFCC	Bolts Geschraubt Boulonné Bulloni
200	4	200	60	4		60	7		XBQ020...	XFCC	
250	4	250	60	5		60	7		XBQ025...	XFCC	
300	6	300	114	5		114	7		XBQ030...	XFCC	
350	6	350	114	5		114	7		XBQ035...	XFCC	
400	6	400	114	6		114	7		XBQ040...	XFCC	
500	6	500	114	6		114	7		XBQ050...	XFCC	
600	6	600	168	8		168	7		XBQ060...	XFCC	

Contact the Manufacturer - *Beim Hersteller nachfragen*
 Consulter le Fabricant - *Consultare il Costruttore*

MU_P

Ø	L (m)	Inlet end bearing for drive at outlet <i>Einlaufendlager bei auslaufs. Antr. Palier entrée avec motoris. à la sortie Testata carico per motorizz. lato carico</i>	Outlet end bearing for drive at inlet <i>Auslaufendlager bei einlaufs. Antriebe Palier sortie avec motoris. à l'entrée Testata scarico per motorizz. lato scarico</i>	Inlet shaft coupling <i>Wellenverbindung einlaufseitig Accouplement entrée Accoppiamento carico</i>	Outlet shaft coupling <i>Wellenverbindung auslaufseitig Accouplement sortie Accoppiamento scarico</i>	Sealing <i>Wellenabdichtung Etanchéité Tenuta</i>
150	3	XSP035B_1	XSP035A_1	XAA040T0601	XAA040T0601	XUC045B1
200	3	XSP035B_1	XSP035A_1	XAA040T0601	XAA040T0601	XUC045B1
250	3	XSP045B_1	XSP045A_1	XAA048T0601	XAA048T0601	XUC055B1
300	4	XSP055B_1	XSP055A_1	XAA060T1141	XAA060T1141	XUC070B1
350	4	XSP055B_1	XSP055A_1	XAA060T1141	XAA060T1141	XUC070B1
400	3.5	XSP055B_1	XSP055A_1	XAA060T1141	XAA060T1141	XUC070B1
500	3	XSP065B_1	XSP065A_1	XAA075T1141	XAA075T1141	XUC080B1
600	4	XSP065B_1	XSP065A_1	XAQ075T1681	XAQ075T1681	XUC080B1

Contact the Manufacturer - *Beim Hersteller nachfragen*
 Consulter le Fabricant - *Consultare il Costruttore*

MU_E

Ø	L (m)	Inlet end bearing for drive at outlet <i>Einlaufendlager bei auslaufs. Antr. Palier entrée avec motoris. à la sortie Testata carico per motorizz. lato carico</i>	Outlet end bearing for drive at inlet <i>Auslaufendlager bei einlaufs. Antriebe Palier sortie avec motoris. à l'entrée Testata scarico per motorizz. lato scarico</i>	Inlet shaft coupling <i>Wellenverbindung einlaufseitig Accouplement entrée Accoppiamento carico</i>	Outlet shaft coupling <i>Wellenverbindung auslaufseitig Accouplement sortie Accoppiamento scarico</i>	Sealing <i>Wellenabdichtung Etanchéité Tenuta</i>
150	3	XSR035B_1	XSR035A_1	XAV085T0601	XAV085T0601	XUC045B1
200	3	XSR035B_1	XSR035A_1	XAV085T0601	XAV085T0601	XUC045B1
250	3	XSR045B_1	XSR045A_1	XAV100T0601	XAV100T0601	XUC055B1
300	4	XSR055B_1	XSR055A_1	XAV125T1141	XAV125T1141	XUC070B1
350	4	XSR055B_1	XSR055A_1	XAV125T1141	XAV125T1141	XUC070B1
400	3.5	XSR055B_1	XSR055A_1	XAV125T1141	XAV125T1141	XUC070B1
500	3	XSR065B_1	XSR065A_1	XAV125T1141	XAV125T1141	XUC080B1
600	4	XSR065B_1	XSR065A_1	XAT125T1681	XAT125T1681	XUC080B1

Contact the Manufacturer - *Beim Hersteller nachfragen*
 Consulter le Fabricant - *Consultare il Costruttore*

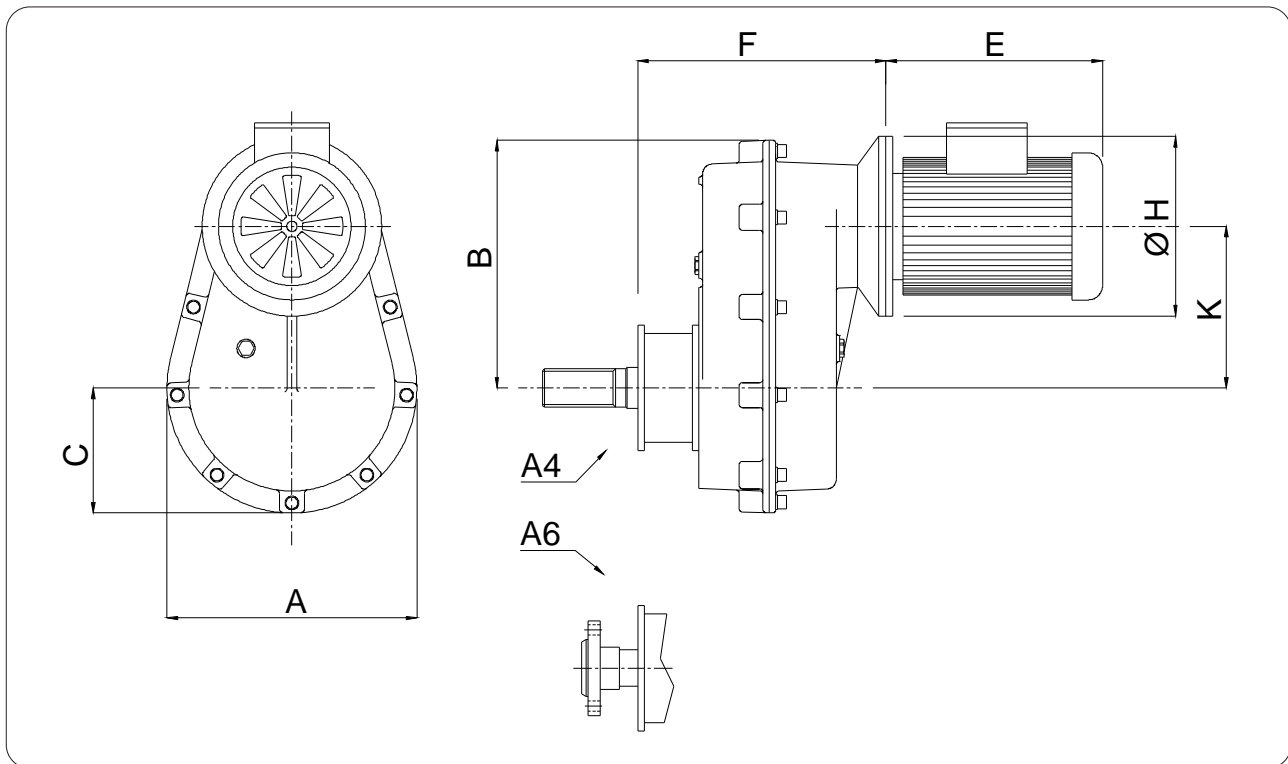

S 21							
kW	A	B	C	E	F	H	K
0.75	192	220	100	240	225	200	143
1.1	192	220	100	280	225	200	143
1.5	192	220	100	280	225	200	143

S 23							
kW	A	B	C	E	F	H	K
0.75	226	280	115	240	247	200	180
1.1	226	280	115	240	247	200	180
1.5	226	280	115	280	247	200	180
2.2	226	280	115	305	247	250	180
3.0	226	280	115	305	247	250	180

S 25							
kW	A	B	C	E	F	H	K
1.1	256	290	128	240	280	200	180
1.5	256	290	128	280	280	200	180
2.2	256	290	128	305	280	250	180
3.0	256	290	128	305	280	250	180
4.0	256	290	128	340	280	250	180
5.5	256	290	128	380	280	300	180

S 27							
kW	A	B	C	E	F	H	K
7.5	352	430	180	410	326	300	285
9.2	352	430	180	410	326	300	285
11.0	352	430	180	485	326	350	285

2
 SCREWS - WENDEL - SPIRES - ELICHE

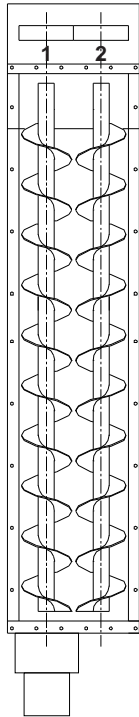

Outlet - *Auslauf*
 Sortie - *Scarico*

Inlet - *Einlauf*
 Entrée - *Carico*

Drive unit at inlet, direct, 1 to LH.
 Gear transmission at outlet.

*1 Direktantrieb am Einlaufend links,
 Übersetzungsvorgelege am Auslauf.*

Motorisation au chargement en direct 1 à g.
 Renvoi sur la sortie.

*Motorizzazione al carico in diretta 1 a sx.
 Rinvio allo scarico.*

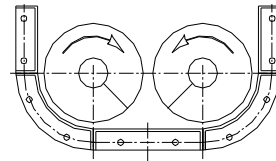

View from inlet - *Ansicht von Einlauf*
 Vue de chargement - *Vista da carico*

3
 SCREWS - WENDEL - SPIRES - ELICHE

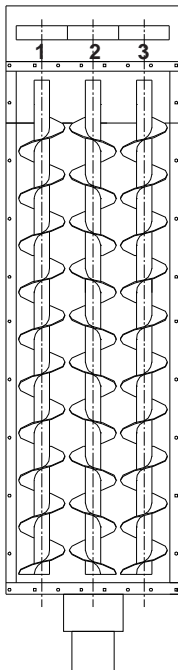

Outlet - *Auslauf*
 Sortie - *Scarico*

Inlet - *Einlauf*
 Entrée - *Carico*

Drive unit at inlet, direct, 1 central.
 Gear transmission at outlet.

*1 Direktantrieb am Einlauf zentral,
 Übersetzungsvorgelege am Auslauf.*

Motorisation au chargement en direct 1 central.
 Renvoi sur la sortie.

*Motorizzazione al carico in diretta 1 centrale.
 Rinvio allo scarico.*

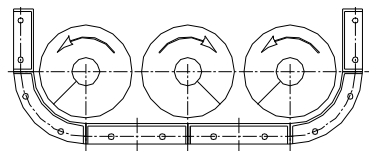

View from inlet - *Ansicht von Einlauf*
 Vue de chargement - *Vista da carico*

4
 SCREWS - WENDEL - SPIRES - ELICHE

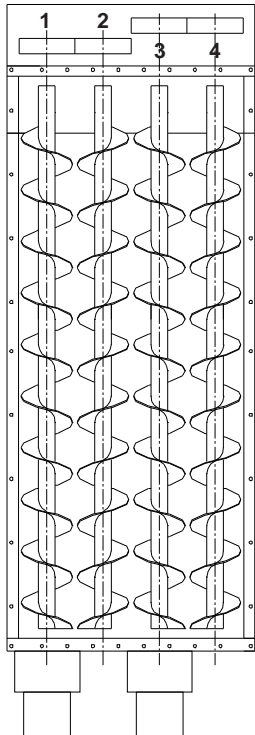

Outlet - *Auslauf*
 Sortie - *Scarico*

Inlet - *Einlauf*
 Entrée - *Carico*

2 drive units at inlet end, direct to LH of each group of 2.
 Gear transmission at outlet.

*2 Direktantriebe am Einlaufende links von jeder Zweiergruppe
 Übersetzungsvorgelege am Auslauf.*

Motorisation 2 au chargement en direct à g. de chaque groupe de 2
 Renvoi sur la sortie.

*Motorizzazione 2 al carico in diretta a sx di ogni gruppo da 2
 Rinvio allo scarico.*

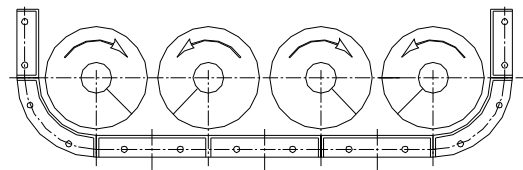

View from inlet - *Ansicht von Einlauf*
 Vue de chargement - *Vista da carico*

5
 SCREWS - WENDEL - SPIRES - ELICHE

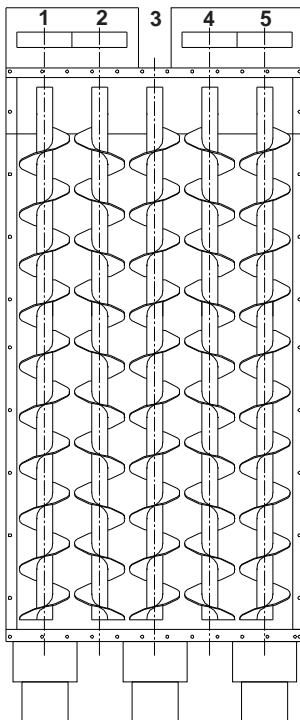

Outlet - *Auslauf*
 Sortie - *Scarico*

Inlet - *Einlauf*
 Entrée - *Carico*

Drive unit with 3 motors, 2 on sides, 1 central.
 Int. gear at outlet on two outer units

*3 Antriebe, 2 seitliche, 1 zentraler, einlaufseitig
 Übersetzungsvorgelege am Auslaufende an den beiden außen
 liegenden Wendelpaaren*

Motorisation à 3 moteurs, 2 latéraux 1 central
 Renvoi côté déchargement sur deux groupes extérieurs

*Motorizzazione a 3 motori, 2 laterali 1 centrale
 Rinvio lato scarico sui due gruppi esterni*

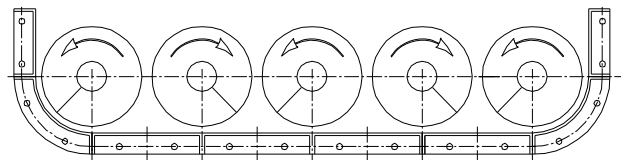

View from inlet - *Ansicht von Einlauf*
 Vue de chargement - *Vista da carico*

6
 SCREWS - WENDEL - SPIRES - ELICHE

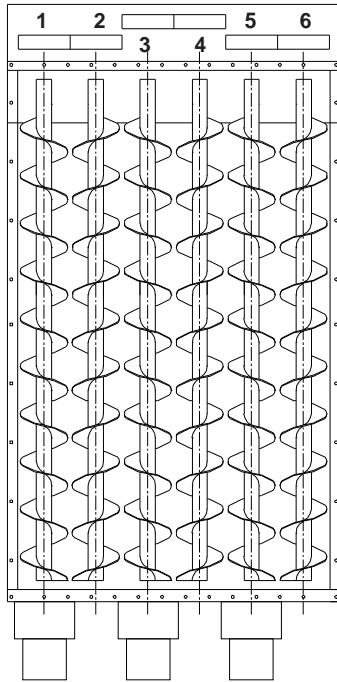

Outlet - *Auslauf*
 Sortie - *Scarico*

Drive unit with 3 motors.
 Loading side to LH of each group of 2

*3 Antriebe,
 einlaufseitig links von jedem Wendelpaar*

Motorisation à 3 moteurs
 Côté chargement à g. de chaque groupe de 2

*Motorizzazione a 3 motori
 Lto carico a sx di ogni gruppo da 2*

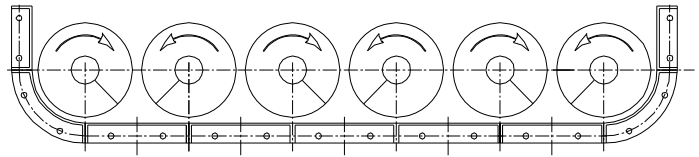

View from inlet - *Ansicht von Einlauf*
 Vue de chargement - *Vista da carico*

Inlet - *Einlauf*
 Entrée - *Carico*

STANDARD

3	T	G	T	G
---	---	---	---	---

Screw conveyor finish class - <i>Finishklasse der Schnecke</i> - <i>Classe de finition vis sans fin</i> - <i>Classe di finitura coclea</i>				
3	Standard	Standard	Standard	Standard
4	High quality	Hochwertig	Soignée	Accurata

Screw finishing treatment - <i>Oberflächenbehandlung Wendel</i> <i>Traitement superficiel de la spire</i> - <i>Trattamento superficiale spira</i>				
0	None	Keine	Aucun	Nessuno
S	Sa 2.5 + 80µm repaintable powder coat (RAL 7001 only)	Sa 2.5 + 80µm Pulverbeschichtung überlackierbar (nur RAL 7001)	Sa 2,5 + 80µm reprise par peinture en poudre possible (RAL 7001 seulement)	Sa 2.5 + 80µm verniciatura a polvere riverniciabile (solo RAL 7001)
T	Sa 2.5 + 80µm powder coat (all RAL hues)	Sa 2.5 + 80µm Pulverbeschichtung (alle RAL-Farbtöne)	Sa 2,5 + 80µm peinture en poudre (toutes les RAL)	Sa 2.5 + 80µm verniciatura a polvere (tutti i RAL)
U	Sa 2.5 + 120µm powder coat (all RAL hues)	Sa 2.5 + 120µm Pulverbeschichtung (alle RAL)	Sa 2,5 + 120µm peinture en poudre (toutes les RAL)	Sa 2.5 + 120µm verniciatura a polvere (tutti i RAL)
V	Sa 2.5 + 80µm food-grade powder coat (RAL 9010 only)	Sa 2.5 + 80µm lebensmitteltaugliche Pulverbeschichtung (nur RAL 9010)	Sa 2,5 + 80µm peinture en poudre alimentaire (RAL 9010 seulement)	Sa 2.5 + 80µm verniciatura a polvere alimentare (solo RAL 9010)
X **	Sa 2.5 + 80µm galvanized powder + 80µm powder coat (all RAL hues)	Sa 2.5 + 80µm Zinkstaubanstrich + 80µm Pulverbeschichtung (alle RAL-Farbtöne)	Sa 2.5 + 80µm zingage aux poudre + 80µm peinture en poudre (toutes les RAL)	Sa 2.5 + 80µm zincante a polvere + 80µm verniciatura a polvere (tutti i RAL)

Screw colour hue - *Farbton Wendel* - *Teintes de la spire* - *Tonalità spira*

 See COLOUR Table - *Siehe Tabelle FARBTÖNE* - Voir la table des TEINTES - *Vedi tabella TONALITA'*

Trough and covers surface treatment - <i>Oberflächenbehandlung Trog und Deckel</i> <i>Traitement superficiel auge et couvercles</i> - <i>Trattamento superficiale truogolo e coperchi</i>				
0	None	Keine	Aucun	Nessuno
S	Sa 2.5 + 80µm repaintable powder coat (RAL 7001 only)	Sa 2.5 + 80µm überlackierbare Pulverbeschichtung (nur RAL 7001)	Sa 2.5 + 80µm reprise avec peinture en poudre possible (RAL 7001 seulement)	Sa 2.5 + 80µm verniciatura a polvere riverniciabile (solo RAL 7001)
T	Sa 2.5 + 80µm powder coat (all RAL paint hues)	Sa 2.5 + 80µm Pulverbeschichtung (alle RAL-Töne)	Sa 2.5 + 80µm peinture en poudre (toutes les RAL)	Sa 2.5 + 80µm verniciatura a polvere (tutti i RAL)
U	Sa 2.5 + 120µm powder coat (all RAL paint hues)	Sa 2.5 + 120µm Pulverbeschichtung (alle RAL-Töne)	Sa 2.5 + 120µm peinture en poudre (toutes les RAL)	Sa 2.5 + 120µm verniciatura a polvere (tutti i RAL)
V	Sa 2.5 + 80µm food-grade powder coat (RAL 9010 only)	Sa 2.5 + 80µm lebensmittelechte Pulverbeschichtung (nur RAL 9010)	Sa 2.5 + 80µm peinture en poudre alimentaire (RAL 9010 seulement)	Sa 2.5 + 80µm verniciatura a polvere alimentare (solo RAL 9010)
X **	Sa 2.5 + 80µm galvanized powder + 80µm powder coat (all RAL paint hues)	Sa 2.5 + 80µm Zinkstaubanstrich + 80µm Pulverbeschichtung (alle RAL-Töne)	Sa 2.5 + 80µm zingage aux poudre + 80µm peinture en poudre (toutes les RAL)	Sa 2.5 + 80µm zincante a polvere + 80µm verniciatura a polvere (tutti i RAL)

Colour hues of trough and covers - *Farbtöne Trog und Deckel* - *Teintes auge et couvercles* - *Tonalità truogolo e coperchi*

 See COLOURS' Table - *Siehe Tabelle FARBTÖNE* - Voir la table des TEINTES - *Vedi tabella TONALITA'*

The type of surface treatment and internal colour of the trough and covers MUST NOT be different from the external paint.

Der Typ der Oberflächenbehandlung und der Tonalität im Troginnen und der Deckel KANN NICHT VON der externen ABWEICHEN.

Le type de traitement superficiel et les teinte interne de l'auge et des couvercles NE POURRA PAS ETRE DIFFERENTE de la teinte extérieure.

Il tipo di trattamento superficiale e la tonalità interna del truogolo e coperchi NON POTRA' ESSERE DIVERSA da quella esterna.

Standard (always in stock) - Serienmäßig (immer auf Lager vorrätig) De série (toujours disponible en stock) - Di serie (sempre disponibili a magazzino)	
A	Caterpillar yellow - <i>Gelb Caterpillar</i> - Jaune caterpillar - <i>Giallo caterpillar</i>
I *	RAL 7001
Fast standard (always in stock) - Serienmäßig schnell (immer auf Lager vorrätig) Standard rapide (toujours disponible en stock) - Standard veloce (sempre disponibili a magazzino)	
0	None - <i>Keine</i> - Aucun - <i>Nessuno</i>
B	RAL 1013
C	RAL 1015
E	RAL 5015
F	RAL 6011
G *	RAL 7035
H	RAL 7032
L	RAL 9001
M	RAL 9002
N	RAL 9010
Q	RAL 1006
4	RAL 2004
Slow standard (purchased from time to time, subject to minimum quantity) Standard langsam (von Fall zu Fall zu erwerben, unterliegen Mindestbestimmungen) Standard lent (achetés au cas par cas, fournis en quantité minimum) Standard lenta (acquistati di volta in volta, soggetti a quantitativo minimo)	
1	Yellow C - <i>Gelb C</i> - Jaune C - <i>Giallo C</i>
6	RAL 5012
D	RAL 5010
V	Others - <i>Andere</i> - Autres - <i>Altri</i> RAL 1007 - 1021 - 2008 - 3002 - 3011 - 3020 - 5000 - 5017 - 6005 - 6018 - 6021 - 6029 - 7000 - 7037 - 7044 - 7047 - 9003 - 9005 - 9016 - 9018

*** Recommended colour**
**** To defined in agreement with the WAM® commercial Dept**
NOTE

- End plate, gear reducers, end bearings and drive bases are painted using HS paint such as RAL 5010 (gentian blue)
- All types of powder treatment (S, T, U, V, X) are suitable for use in applications with max. temperature of 170°C.
- T type painting is suitable for parts working in contact with cereals and flours, or solid food products as they are formulated in accordance with M.D. 21/03/1973 (G.U.No. 104 of 20/04/73) and conform to M.D. 22/07/1998 No. 338.
- V type painting is suitable for parts working in contact with food products according to the provisions of M.D. 21/03/1973 and successive updates derived from Directives 2001/62/EC, 2002/16/EC, 2002/17/EC.
- CAV 600 will be liquid-painted (see sect.4)
- For painting other than that indicated, contact the Manufacturer.

*** Empfohlene Tonalität**
**** Mit dem Verkaufsbüro von WAM® zu vereinbaren.**
ANMERKUNGEN

- Zwischenlagerträger, Antriebsköpfe, Endlager und Konsolen für die Getriebe sind mit HOCHFESTEM Lack RAL 5010 (Enzianblau) lackiert.
- Alle Arten der Pulverbeschichtung (S,T,U,V,X) eignen sich für Anwendungen mit max. Temperatur von 170°C.
- Die Lackierung Typ T eignet sich zum Arbeiten in Berührung mit Getreide und Mehl oder auf jeden Fall mit festen Nahrungsmitteln, weil die gemäß des D.M. 21/03/1973 (G.U.N 104 vom 20/04/73) formuliert sind und dem D.M. 22/07/1998 Nr. 338 konform sind.
- Die Lackierung Typ V eignet sich zum Arbeiten in Berührung mit Nahrungsmitteln gemäß der Bestimmungen des D.M. 21/03/1973 und der anschließenden Änderungen aufgrund der Richtlinien 2001/62/EG, 2002/16/EG, 2002/17/EG.
- CAV 600 wird flüssig lackiert (siehe Kap. 4)
- Für unterschiedliche Lackierungen muss man sich an den Hersteller wenden.

*** Teinte conseillée**
**** A convenir avec le service commercial WAM®.**
REMARQUES

- Porte palier, têtes motrices, paliers d'extrémité et bâtis pour les transmissions sont peintes uniquement avec des peintures A HAUT EXTRAIT SEC RAL 5010 (bleu gentiane).
- Tous les types de traitements en poudre (S,T,U,V,X) sont indiqués pour travailler dans des applications à une température maximum de 170°C.
- la peinture type T est indiquée pour travailler en contact avec des céréales, des farines ou des produits alimentaires solides car formulées conformément au D.M 21/03/1973 (G.U.N 104 du 20/04/73) et au D.M 22/07/1998 n°338.
- la peinture type V est indiquée pour travailler en contact de produits alimentaires conformément aux prescriptions du D.M 21/03/1973 et mises à jours successives tirées des directives 2001/62/CE, 2002/16/CE, 2002/17/CE.
- CAV 600 sera peint à liquide (voir chap.4)
- Pour des peintures différentes de celles indiquées, veuillez contacter le Constructeur.

*** Tonalità consigliata**
**** Da concordare con ufficio commerciale WAM®.**
NOTE

- Portasupporto, testate motrici, supporti di estremità e basamenti per le trasmissioni sono verniciati con vernice ALTO SOLIDO RAL 5010 (blu genziana)
- Tutti i tipi di trattamenti a polvere (S,T,U,V,X) sono idonei per lavorare in applicazioni con temperatura max di 170°C.
- la verniciatura tipo T è idonea per lavorare a contatto con cereali e farine, o comunque alimentari solidi in quanto sono formulati secondo D.M 21/03/1973 (G.U.N 104 del 20/04/73) e conformi al D.M 22/07/1998 n°338.
- la verniciatura tipo V è idonea per lavorare a contatto con prodotti alimentari secondo quanto previsto da D.M 21/03/1973 e successivi aggiornamenti derivati da direttive 2001/62/CE, 2002/16/CE, 2002/17/CE.
- CAV 600 sarà verniciata a liquido (vedere cap.4)
- Per verniciature diverse da quelle indicate, contattare il Costruttore.

2nd GROUP
DRIVE UNIT

2. GRUPPE
ANTRIEB

2^E GROUPE
MOTORISATION

2° GRUPPO
MOTORIZZAZIONE

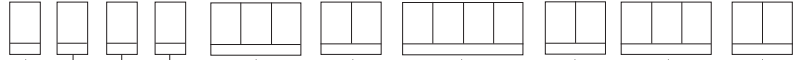
MU

N° Drive - Antriebs - Motorisation - Motorizzazioni

1 - 2 - 3 - 4 - 5 - 6

Drive position - Antriebsanordnung
Position motorisation - Posizione motorizzazione

C = inlet end - *einlaufseitig* - côté d'entrée - *coda*
 T = outlet end - *auslaufseitig* - côté de sortie - *testa*

Transmission type - Typ Kraftübertragung
Type d'entraînement - Tipo di trasmissione

+ = direct - *direkt* - *directe* - *diretta*
 L = coupling - *Kupplung* - *accouplement* - *giunto*
 A = chain - *Kette* - *chaîne* - *catena* 1:1
 B = chain - *Kette* - *chaîne* - *catena* 1:1.25
 C = chain - *Kette* - *chaîne* - *catena* 1:1.56
 D = chain - *Kette* - *chaîne* - *catena* 1:2
 S = belt - *Riemen* - *courroie* - *cinghia* 1:1
 T = belt - *Riemen* - *courroie* - *cinghia* 1:1.25
 U = belt - *Riemen* - *courroie* - *cinghia* 1:1.56
 V = belt - *Riemen* - *courroie* - *cinghia* 1:2

Mount position - Position Konsole
Position du bâti - Posizione basamento

Direct drive
Direktantrieb + = without - *ohne* - sans - *senza*
 Entraînement direct
Trasm. diretta

Belt drive
Riementrieb A = high - *oben* - en haut - *in alto*
 Entraînem. par courroie
Trasm. cinghia

Drive Coupling
Kupplungsantrieb L = in line - *Reihentyp* - en ligne - *in linea*
 Entraînem. par accoupl.
Trasm. giunto

Chain drive
Kettenantrieb N = north - *Norden* - nord - *nord*
 S = south - *Süden* - sud - *sud*
 Entraînem. par chaîne
Trasm. catena E = east - *Osten* - est - *est*
 W = west - *Westen* - ouest - *ovest*

Gear reducer - Getriebe - Réducteur - Riduttore

S21 - S23 - S25 - S27

Gear ratio - Untersetzungsverhältnis
Rapport de réduction - Rapporto di riduzione

10 - 12 - 16 - 20 - 25 - 30 - 40

Power - Leistung - Puissance - Potenza

0110 - 0150 - 0220 - 0300 - 0400 - 0550
 0750 - 0920 - 1100 - 1500 - 1850 - 2200

(daw)

Poles - Pole - Pôles - Poli

04 = 4
 48 = 4/8

Voltage supply - Betriebsspannung
Voltage d'alimentation - Tensione di alimentazione

+++ = no WAM
 260 = 260 - 440 V
 240 = 240 - 415 V
 230 = 230 - 400 V
 200 = 200 - 345 V

Cycles - Frequenz - Fréquence - Frequenza

50 = 50Hz
 60 = 60 Hz
 ++ = non WAM

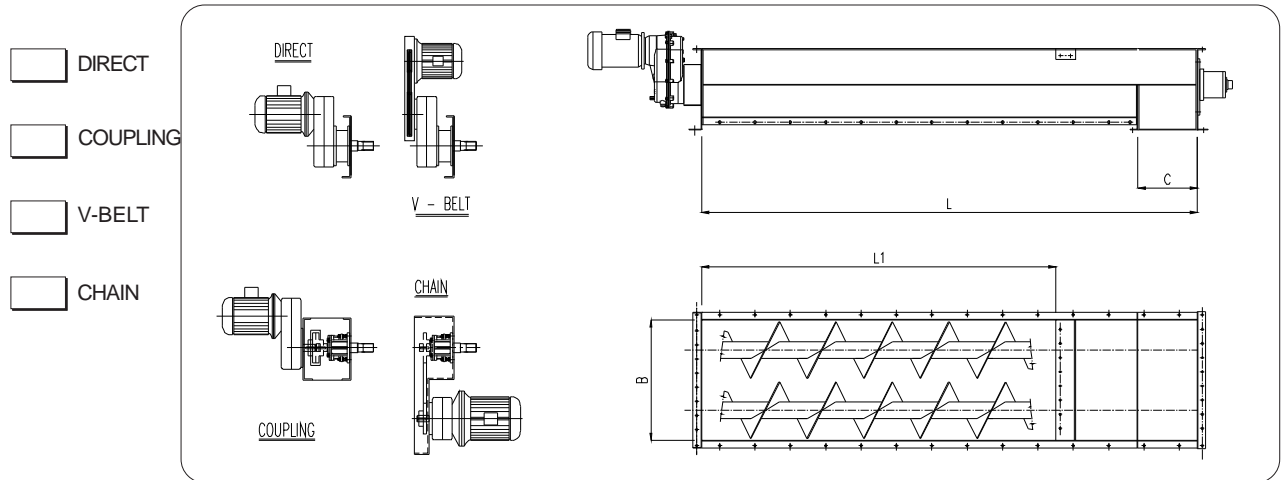
PRODUCT

Description	
Bulk Density [t/m ³]	
Particle Size	mm <input type="text"/> µm <input type="text"/>
Flowability	Very Free Flowing <input type="checkbox"/> Free Flowing <input type="checkbox"/> Average <input type="checkbox"/> Poorly <input type="checkbox"/>
Abrasiveness	Mildly <input type="checkbox"/> Moderately <input type="checkbox"/> Extremely <input type="checkbox"/>
Temperature [C°]	
Hazard properties	

SCREW

Conveyor	<input type="text"/> from	<input type="text"/> to
Feeder	<input type="text"/> from	<input type="text"/> to
Throughput rate (m ³ /h)	<input type="text"/>	
Material column height [m]	<input type="text"/>	
Length [mm]	L = <input type="text"/>	
Inclination [α°]	<input type="text"/>	
Diameter on Request	ø T = <input type="text"/>	
Inlet spout length	L1 = <input type="text"/>	
Outlet spout	C = <input type="text"/>	Std <input type="checkbox"/> Special <input type="checkbox"/>

OPERATION

Continuous	<input type="checkbox"/>	Hours/Day <input type="text"/>	Days/Year <input type="text"/>
Batch-type	<input type="checkbox"/>	Start ups/Hour <input type="text"/>	Hours/Day <input type="text"/>
Type of Plant	Indoor <input type="checkbox"/> Outdoor <input type="checkbox"/>		

DRIVE

Drive Position	Inlet <input type="checkbox"/>	Outlet <input type="checkbox"/>
Voltage [V]	<input type="text"/>	
Frequency [Hz]	50 <input type="checkbox"/>	60 <input type="checkbox"/>

OPTIONS

REMARKS

- DIRECT
 COUPLING
 V-BELT
 CHAIN

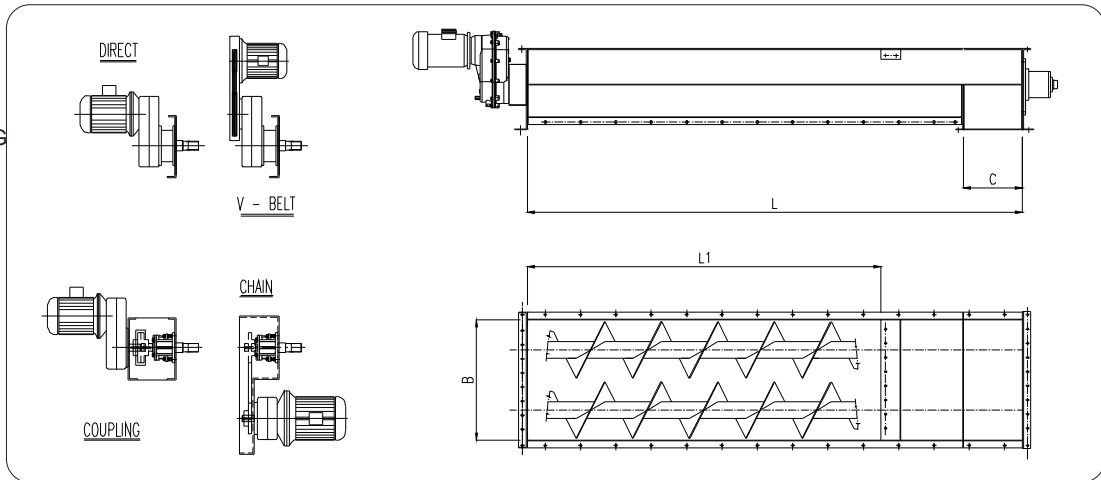

PRODUKT	
Bezeichnung	
Schüttgewicht [t/m ³]	
Rieselfähigkeit	mm
Korngröße	μm
	sehr hoch <input type="checkbox"/> hoch <input type="checkbox"/> mittelmäßig <input type="checkbox"/> schwach <input type="checkbox"/>
Abrasivität	niedrig <input type="checkbox"/> mittelmäßig <input type="checkbox"/> hoch <input type="checkbox"/>
Temperatur [C°]	
Risikoeigenschaften	

SCHNECKE		
Förder-	<input type="checkbox"/> Von	bis
Austrag-	<input type="checkbox"/> Von	bis
Durchsatz [m ³ /h]		
Höhe Materialsäule [m]		
Länge [mm]	L =	
Einbauwinkel [α°]		
Durchmesser (Wunsch)	∅ T =	
Länge Einlauf	L1 =	
Auslauf	C =	Standard <input type="checkbox"/> Spezial <input type="checkbox"/>

BETRIEB	
Dauerbetrieb	<input type="checkbox"/> Stunden pro Tag <input type="checkbox"/> Tage pro Jahr <input type="checkbox"/>
Chargenbetrieb	<input type="checkbox"/> Einsch. pro Std. <input type="checkbox"/> Stunden pro Tag <input type="checkbox"/>
Anlagenaufstellung	im Gebäude <input type="checkbox"/> im Freien <input type="checkbox"/>

ANTRIEB	
Position	Einlauf <input type="checkbox"/> Auslauf <input type="checkbox"/>
Spannung [V]	
Frequenz [Hz]	50 <input type="checkbox"/> 60 <input type="checkbox"/>

OPTIONEN	

ANMERKUNGEN	

- DIRECT
- COUPLING
- V-BELT
- CHAIN

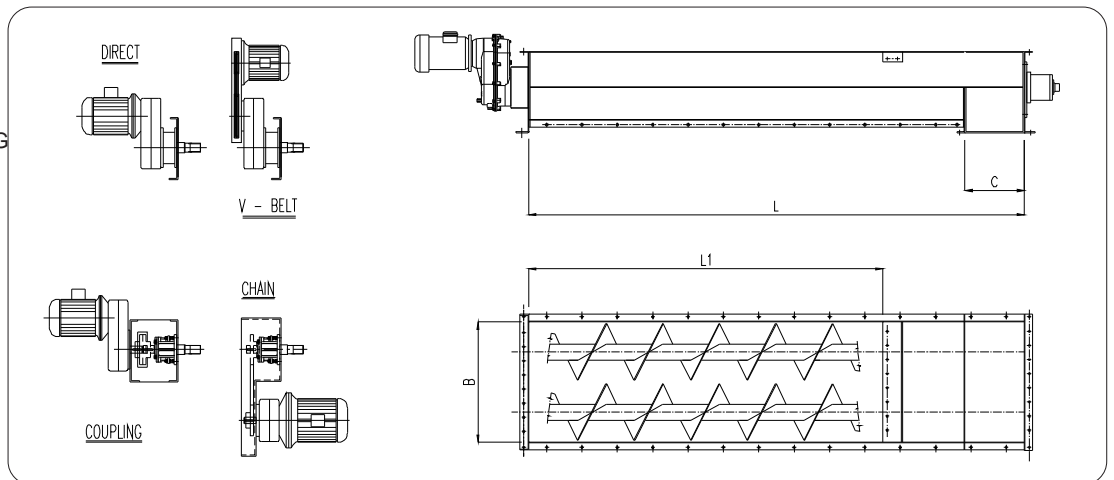
PRODUIT

Désignation				
Densité appar. [t/m³]				
Granulométrie	mm			µm
Fluidité	Très fluide	<input type="checkbox"/>	Fluide	<input type="checkbox"/> Moyenne <input type="checkbox"/> Stagnante <input type="checkbox"/>
Abrasivité	Moyenne	<input type="checkbox"/>	Modérée	<input type="checkbox"/> Extrême <input type="checkbox"/>
Température [C°]				
Propriétés ou dangers				

VIS

Convoyeuse	<input type="checkbox"/>	De		à	
Extractrice	<input type="checkbox"/>	De		à	
Débit [m³/h]					
Hauteur colonne matériau [m]					
Longueur [mm]	L =				
Longueur [mm]					
Diamètre (si demandé)	∅ T =				
Longu. bouche entrée	L1 =				
Bouche sortie	C =	Std	<input type="checkbox"/>	Spécial	<input type="checkbox"/>

SERVICE

Continu	<input type="checkbox"/>	Heures par jour	<input type="checkbox"/>	Jours/ans	<input type="checkbox"/>
Discontinu	<input type="checkbox"/>	Démar./heure	<input type="checkbox"/>	Heures par jour	<input type="checkbox"/>
Type d'installation				Intérieur	<input type="checkbox"/> Extérieur <input type="checkbox"/>

COMMANDE

Pos. motorisation	Chargt.	<input type="checkbox"/>	Déchargt.	<input type="checkbox"/>
Tension [V]				
Fréquence [Hz]	50	<input type="checkbox"/>	60	<input type="checkbox"/>

OPTIONAL

REMARQUES

- DIRECT
 COUPLING
 V-BELT
 CHAIN

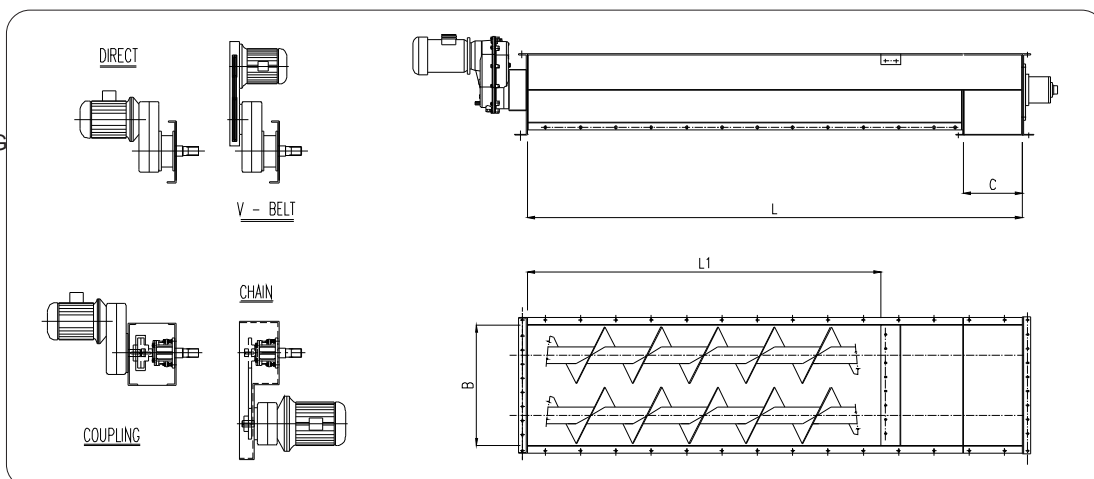

PRODOTTO	
Nome	
Densità apparente [t/m ³]	
Granulometria	mm µm
Scorrevolezza	Molto alta <input type="checkbox"/> Alta <input type="checkbox"/> Media <input type="checkbox"/> Scarsa <input type="checkbox"/>
Abrasività	Bassa <input type="checkbox"/> Media <input type="checkbox"/> Alta <input type="checkbox"/>
Temperatura [C°]	
Proprietà a rischio	

COCLEA	
Convogliatrice	<input type="checkbox"/> Da a
Estrattrice	<input type="checkbox"/> Da a
Portata [m ³ /h]	
Altezza colonna materiale [m]	
Lunghezza [mm]	L =
Inclinazione [α°]	
Diametro se richiesto	∅ T =
Lungh. bocca carico	L1 =
Bocca scarico	C = std <input type="checkbox"/> Speciale <input type="checkbox"/>

ESERCIZIO	
Continuo	<input type="checkbox"/> Ore al giorno <input type="checkbox"/> Giorni l'anno <input type="checkbox"/>
Discontinuo	<input type="checkbox"/> Avvi l'ora <input type="checkbox"/> Ore al giorno <input type="checkbox"/>
Tipo di impianto	Interno <input type="checkbox"/> Esterno <input type="checkbox"/>

COMANDO	
Pos. motorizzazione	Carico <input type="checkbox"/> Scarico <input type="checkbox"/>
Tensione [V]	
Frequenza [Hz]	50 <input type="checkbox"/> 60 <input type="checkbox"/>

OPTIONAL	

NOTE	

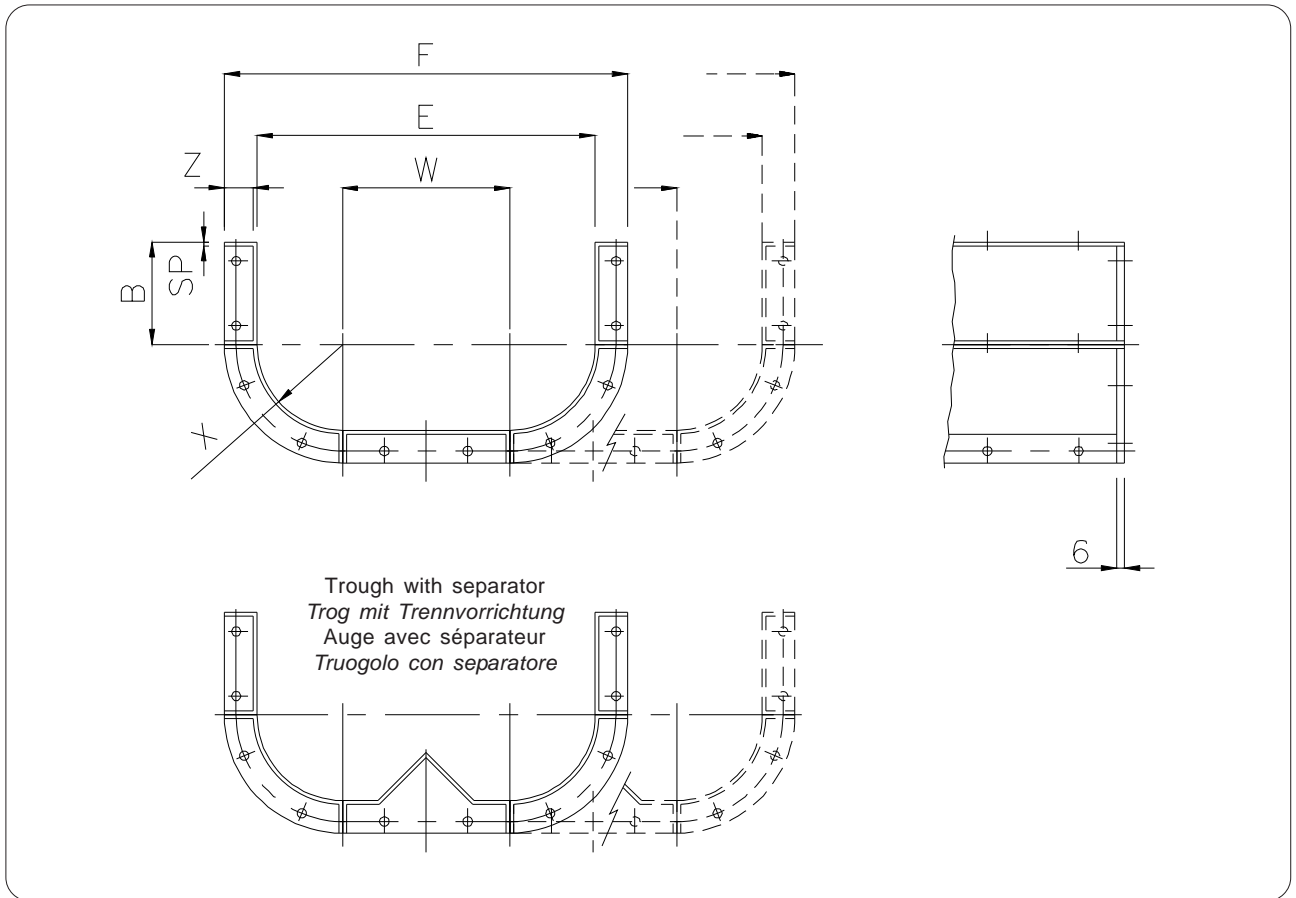

Ø	CODE	F					E					W					B	X	SP	Z	Weight - Gewicht Poids - Peso (kg/m)				
		2EL	3EL	4EL	5EL	6EL	2EL	3EL	4EL	5EL	6EL	2EL	3EL	4EL	5EL	6EL					2EL	3EL	4EL	5EL	6EL
150	XC_.....	428	591	756	921	1086	340	505	670	835	1000	165	330	495	660	825	115	87.5	3	40	19.4	23.9	28.1	32.3	36.8
200	XC_.....	531	751	971	1191	1411	445	665	885	1105	1325	220	440	660	880	1100	135	112.5	3	40	23.9	29.5	35.2	40.5	46.5
250	XC_.....	631	901	1171	1441	1711	545	815	1085	1355	1625	270	540	810	1080	1350	160	137.5	3	40	28.1	34.8	41.3	48.2	55
300	XC_.....	753	1073	1393	1713	2043	645	965	1285	1605	1925	320	640	960	1280	1600	195	162.5	4	50	47.2	58.8	70.2	81.8	93.2
350	XC_.....	863	1243	1623	2003	2383	755	1135	1515	1895	2275	380	760	1140	1520	1900	235	187.5	4	50	52.1	64.7	77.1	89.6	101
400	XC_.....	958	1383	1808	2233	2658	850	1275	1700	2125	2550	425	850	1275	1700	2125	270	212.5	4	50	59.5	73.5	88.1	103	117

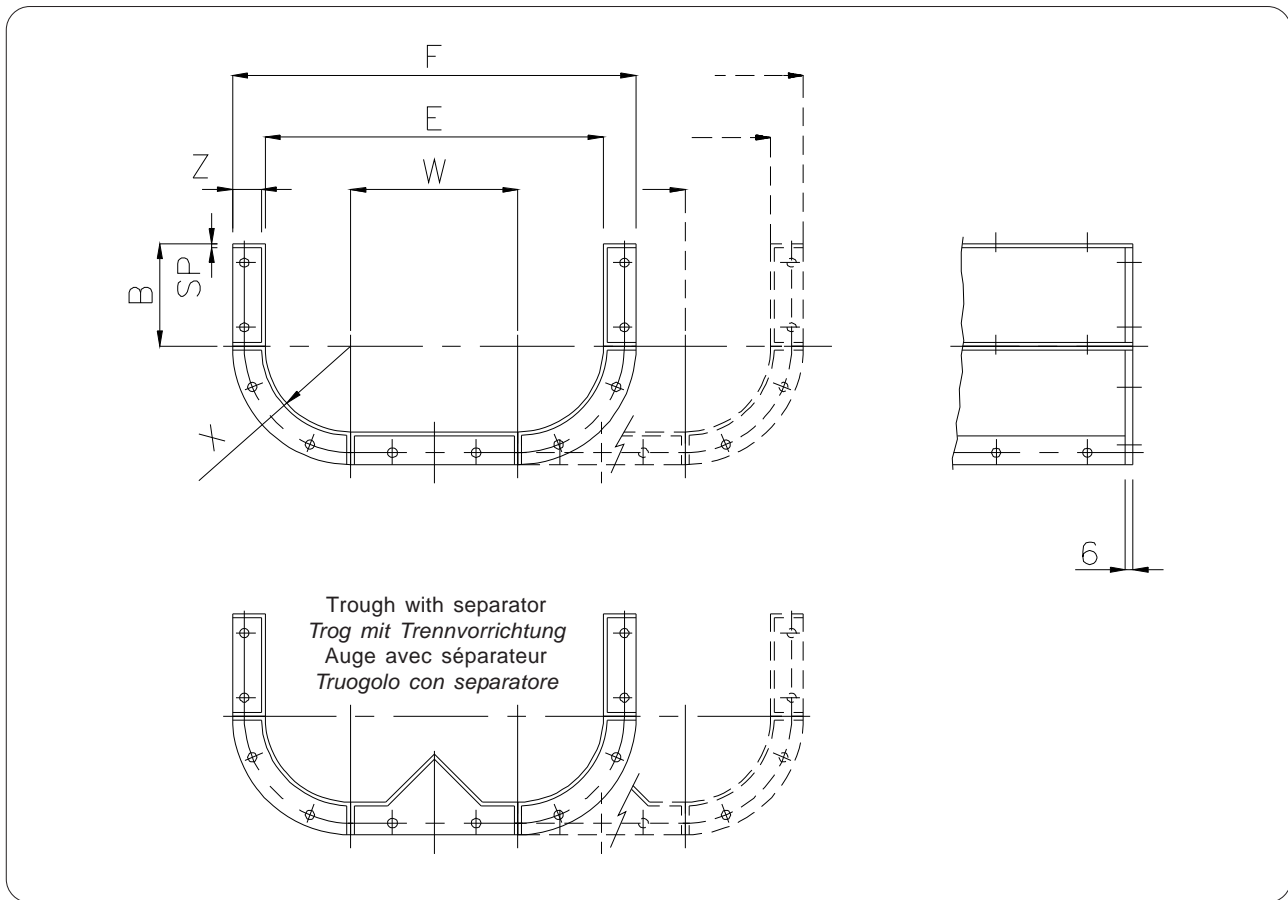

Ø	CODE	F					E					W					B	X	SP	Z	Weight - Gewicht Poids - Peso (kg/m)				
		2EL	3EL	4EL	5EL	6EL	2EL	3EL	4EL	5EL	6EL	2EL	3EL	4EL	5EL	6EL					2EL	3EL	4EL	5EL	6EL
150	XC_.....	428	593	758	923	1088	340	505	670	835	1000	165	330	495	660	825	115	87.5	4	40	25.9	31.8	37.4	43	49.1
200	XC_.....	533	753	973	1193	1413	445	665	885	1105	1325	220	440	660	880	1100	135	112.5	4	40	31.8	39.3	46.9	54	62
250	XC_.....	633	903	1173	1443	1713	545	815	1085	1355	1625	270	540	810	1080	1350	160	137.5	4	40	37.4	46.4	55	64.3	73.3
300	XC_.....	757	1077	1397	1717	2037	645	965	1285	1605	1925	320	640	960	1280	1600	195	162.5	6	50	70.8	88.2	105.3	122.7	139.8
350	XC_.....	867	1247	1627	2007	2387	755	1135	1515	1895	2275	380	760	1140	1520	1900	235	187.5	6	50	78.2	97	115.6	134.4	152
400	XC_.....	962	1387	1812	2237	2662	850	1275	1700	2125	2550	425	850	1275	1700	2125	270	212.5	6	50	89.2	110.2	132.2	154.2	176
500	XC_.....	1177	1697	2217	2737	3257	1045	1565	2085	2605	3125	520	1040	1560	2080	2600	340	262.5	6	60	112	140	167	194	222
600	XC_.....	1377	1997	2617	3237	3857	1245	1865	2485	3105	3725	620	1240	1860	2480	3100	420	312.5	6	60	134.4	168	200	232	264

Contact the Manufacturer - *Beim Hersteller nachfragen*
 Consulter le Fabricant - *Consultare il Costruttore*

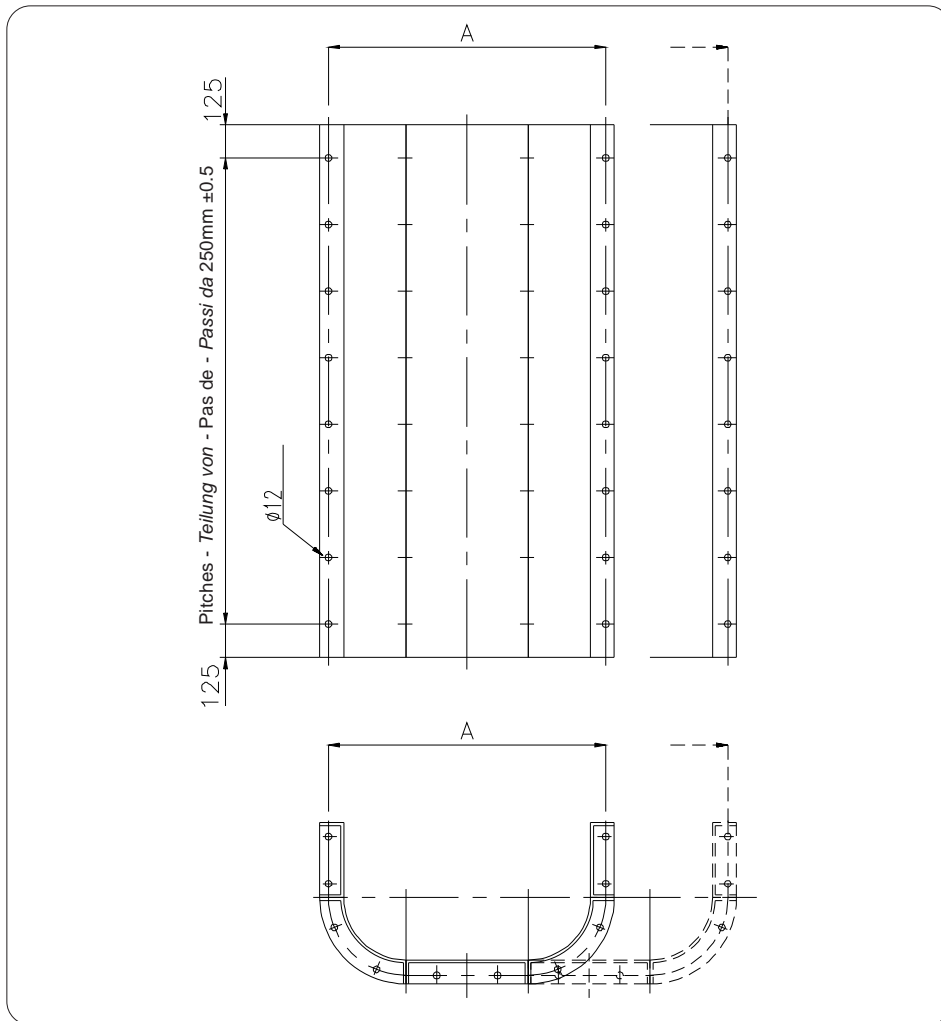

Ø	A				
	2EL	3EL	4EL	5EL	6EL
150	395	560	725	890	1055
200	500	720	940	1160	1380
250	600	870	1140	1410	1680
300	705	1025	1345	1665	1985
350	825	1205	1585	1965	2345
400	925	1350	1775	2200	2625
500	1120	1640	2160	2680	3200
600	1320	1940	2560	3180	3800

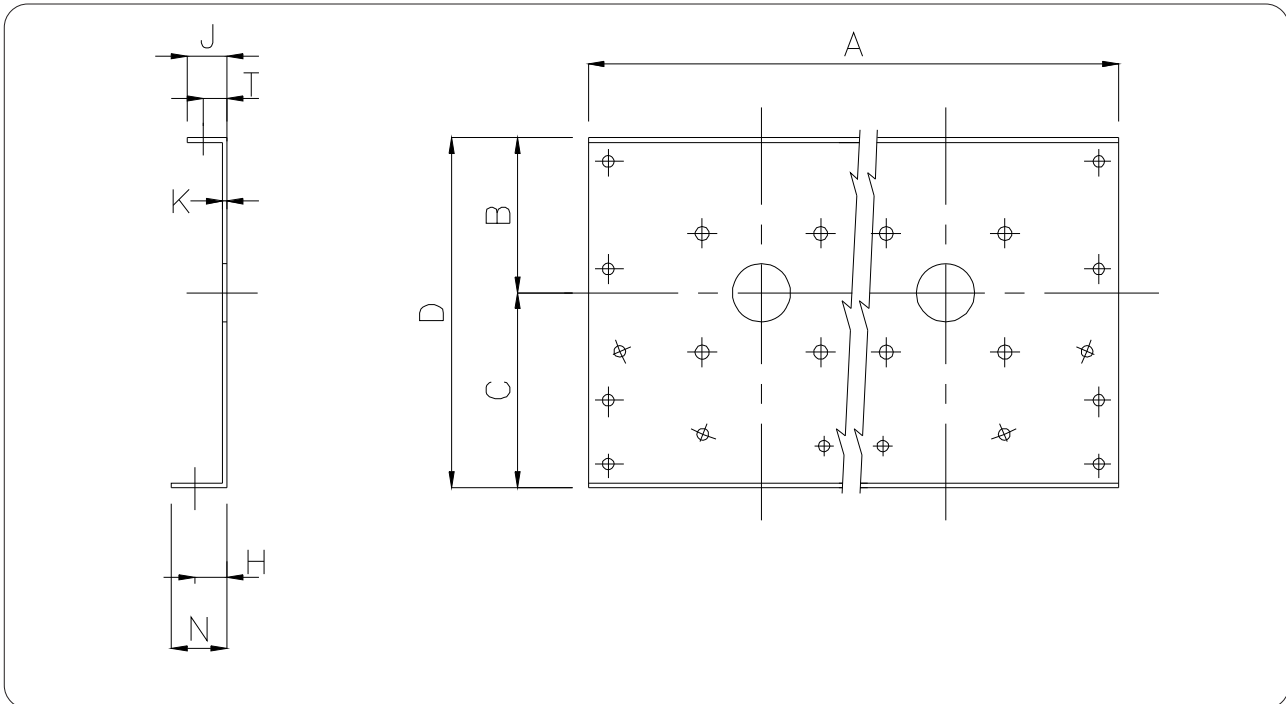

Ø	Code	A					B	C	D	H	K	J	N	T	Weigth - Gewicht Poide - Peso (kg)				
		2 EL	3 EL	4 EL	5 EL	6 EL									2 EL	3 EL	4 EL	5 EL	6 EL
150	XP_0156...	433	598	763	928	1093	115	145	260	30	6	40	50	25	7	10	12.6	15.4	18
200	XP_0206...	535	755	975	1195	1415	135	185	320	30	6	40	50	25	10.3	14.5	18.7	23	27
250	XP_0256...	635	905	1175	1445	1715	160	215	375	40	6	50	70	30	14.7	20.7	26.7	32.8	39
300	XP_0306...	755	1075	1395	1715	2035	195	245	440	40	6	50	70	30	19.7	28	36.4	44.8	53
350	XP_0358...	865	1245	1625	2005	2385	235	275	510	40	8	50	70	30	34	48	62.3	76.4	91
400	XP_0408...	965	1390	1815	2240	2665	270	305	575	45	8	60	80	37.5	43	61.8	80.5	99	118
500	XP_050A...	1175	1695	2215	2735	3255	340	380	720	50	10	60	90	37.5	80	115	150	186	221
600	XP_060A...	1375	1995	2615	3235	3855	420	465	885	55	10	60	100	37.5	112	163	213	264	314

Screws - Wendel	
Hélices - Eliche	
N°	
2	C
3	D
4	E
5	F
6	G

U = section - Querschnitt - section - sezione U
 V = section - Querschnitt - section - sezione V

Drilling upper and lower wings - Lochbild oberer und unterer Flügel
Perçage aile supérieur et inférieure- Foratura ala superiore ed inferiore

Lower wing - *Unterer Flügel*
 Aile inférieure - *Ala inferiore*

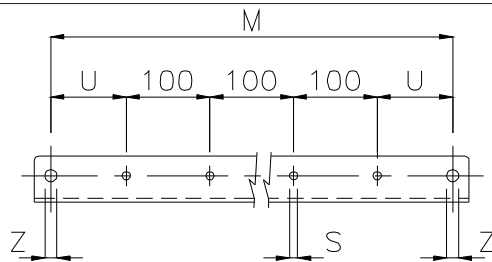

Upper wing - *Oberer Flügel*
 Aile supérieure - *Ala superiore*

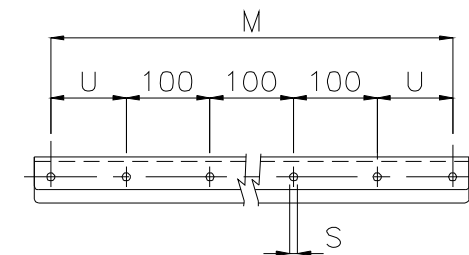

Ø	S	Z*	2EL		3EL		4EL		5EL		6EL	
			M	U	M	U	M	U	M	U	M	U
150	12.5	12.5	395	9705	560	80	725	112.5	890	95	1055	127.5
200	12.5	15	500	100	720	110	940	120	1160	130	1380	140
250	12.5	15	600	100	870	135	1140	120	1410	105	1680	90
300	12.5	19	705	102.5	1025	112.5	1345	122.5	1665	132.5	1985	142.5
350	12.5	19	825	112.5	1205	102.5	1585	92.5	1965	82.5	2345	122.5
400	12.5	19	925	112.5	1350	125	1775	87.5	2200	100	2625	112.5
500	15	24	1120	110	1640	120	2160	140	2680	140	3200	100
600	15	24	1320	110	1540	120	2560	140	3180	140	3800	100

* Only outer drillings of lower wing - *Nur externe Bohrungen des unteren Flügels*
 Trous extérieurs de l'aile inférieure seulement - *Solo fori esterni dell'ala inferiore*

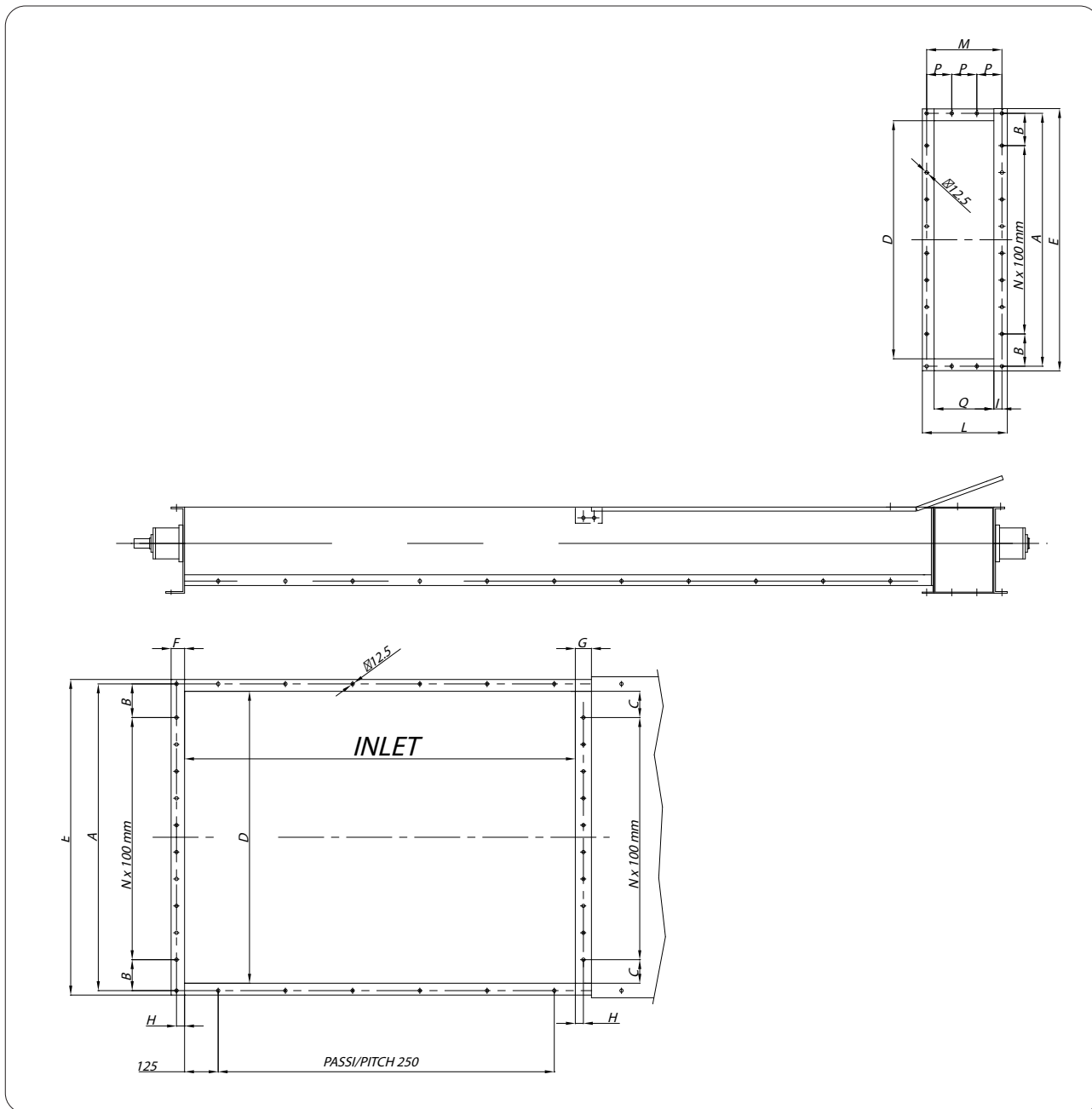
Ø 150

N° Screws - Wendel Hélices - Eliche	A	B	C	D	E	F	G	H	I	L	M	N	P	Q
2	395	97.5	70	340	433	40	50	25	30	266	230	2	115	172.5
3	560	80	52.5	505	598							4		
4	725	112.5	85	670	763							5		
5	890	95	67.5	835	928							7		
6	1055	127.5	100	1000	1093							8		

Ø 200

N° Screws - Wendel Hélices - Eliche	A	B	C	D	E	F	G	H	I	L	M	N	P	Q
2	500	100	72.5	445	535	40	50	25	30	316	280	3	93.3	222.5
3	720	110	82.5	665	755							5		
4	940	120	92.5	885	975							7		
5	1160	130	102.5	1105	1195							9		
6	1380	140	112.5	1325	1415							11		

Ø 250

N° Screws - Wendel Hélices - Eliche	A	B	C	D	E	F	G	H	I	L	M	N	P	Q
2	600	100	72.5	545	635	50	60	30	40	376	330	4	110	262.5
3	870	135	107.5	815	6									
4	1140	120	92.5	1085	9									
5	1410	105	77.5	1355	12									
6	1680	90	62.5	1625	15									

Ø 300

N° Screws - Wendel Hélices - Eliche	A	B	C	D	E	F	G	H	I	L	M	N	P	Q
2	705	102.5	72.5	645	755	50	60	30	40	440	385	5	128.3	315
3	1025	112.5	102.5	965	8									
4	1345	122.5	92.5	1285	11									
5	1665	132.5	102.5	1605	14									
6	1985	142.5	112.5	1925	17									

Ø 350

N° Screws - Wendel Hélices - Eliche	A	B	C	D	E	F	G	H	I	L	M	N	P	Q
2	825	112.5	77.5	755	865	50	60	30	40	490	445	6	89	365
3	1205	102.5	67.5	1135	10									
4	1585	92.5	57.5	1515	14									
5	1965	82.5	47.5	1895	18									
6	2345	122.5	87.5	2275	21									

Ø 400

N° Screws - Wendel Hélices - Eliche	A	B	C	D	E	F	G	H	I	L	M	N	P	Q
2	925	112.5	75	850	965	60	70	37.5	45	553	500	7	100	417.5
3	1350	125	87.5	1275	11									
4	1775	87.5	50	1700	16									
5	2200	100	62.5	2125	20									
6	2625	112.5	75	2550	24									

Ø 500

N° Screws - Wendel Hélices - Eliche	A	B	C	D	E	F	G	H	I	L	M	N	P	Q
2	1120	110	72.5	1045	1175	60	70	37.5	50	668	600	9	120	512.5
3	1640	120	82.5	1565	14									
4	2160	130	92.5	2085	19									
5	2680	140	102.5	2605	24									
6	3200	100	62.5	3125	30									

Ø 600

N° Screws - Wendel Hélices - Eliche	A	B	C	D	E	F	G	H	I	L	M	N	P	Q
2	1320	110	72.5	1245	1375	60	70	37.5	55	773	700	11	140	607.5
3	1940	120	82.5	1865	17									
4	2560	130	92.5	2485	23									
5	3180	140	102.5	3105	29									
6	3800	100	62.5	3725	36									

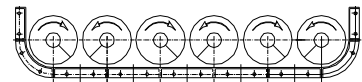
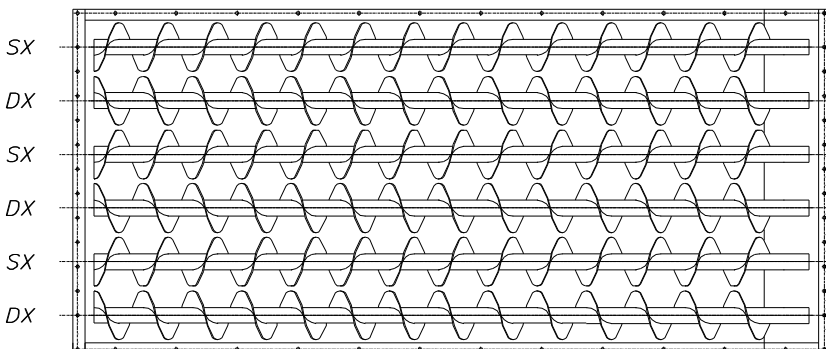
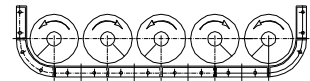
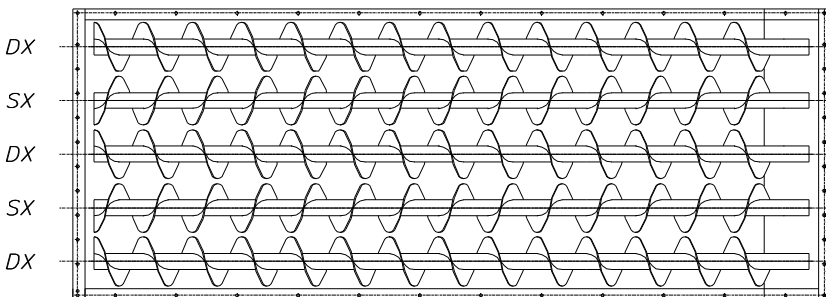
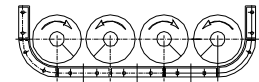
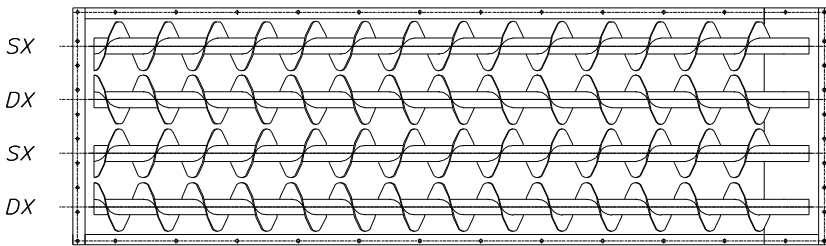
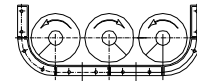
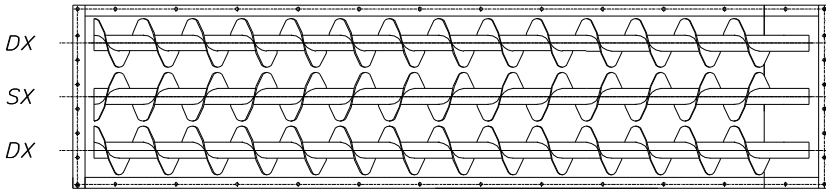
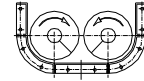
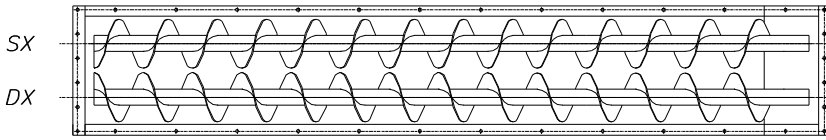
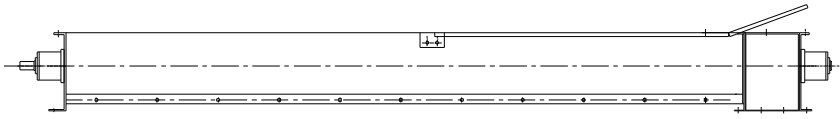

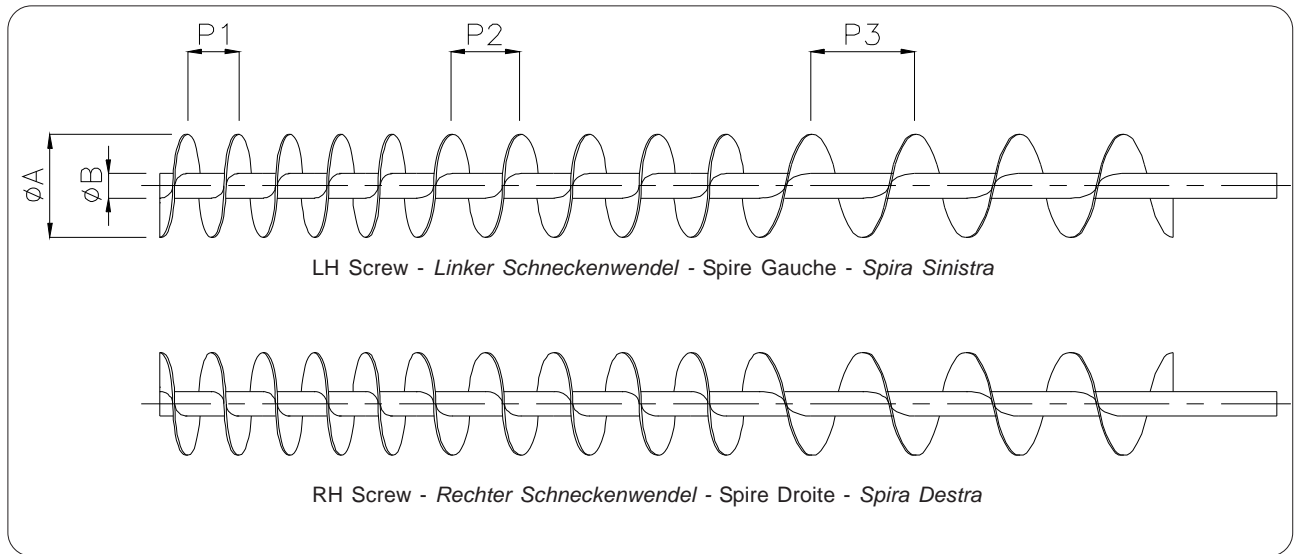

Ø	Code	Ø A	Ø B	P1 (1/2)	P2 (2/3)	P3 (1/1)	Weight - Gewichte Poids - Peso kg/m
150	XE..015.....	150	60	75	100	150	12
200	XE..020.....	200	60	100	133	200	14.3
	XE..020.....		114				22.4
250	XE..025.....	250	60	125	167	250	15.8
	XE..025.....		114				24.1
300	XE..030.....	300	114	150	200	300	25.8
	XE..030.....		168				22
350	XE..035.....	350	114	175	233	350	27.4
	XE..035.....		168				23.5
400	XE..040.....	400	114	200	266	400	31
	XE..040.....		168				27.5
500	XE..050.....	500	114	250	333	500	35.3
	XE..050.....		168				31
600	XE..060.....	600	168	300	400	600	51
	XE..060.....		219				42.5

Note

The pitch values in the Table are approximate: their presence and extension depends on the product to be extracted and the length of the inlet opening.

The pitch refers to a screw with square flight pitch.

Anmerkung

Die Steigungen in der Tabelle sind unverbindlich. Das Vorhandensein oder Nichtvorhandensein und ihre Länge hängt vom auszutragenden Produkt und der Länge des Einlaufs ab.

Die Gewichtsangaben beziehen sich auf die Schneckenwendel mit Steigung 1/1.

Remarque

Les pas de la table sont indicatifs, leur présence ou pas et leur extension dépendent du produit à extraire et de la longueur de l'ouverture de l'entrée de chargement.

Le poids se réfère à la spire avec hélice ayant un pas 1/1.

Nota

I passi in tabella sono indicativi, la loro presenza o meno e la loro estensione dipendono dal prodotto da estrarre e dalla lunghezza dell'apertura di carico.

Il peso è riferito alla spira con elica avente passo 1/1.

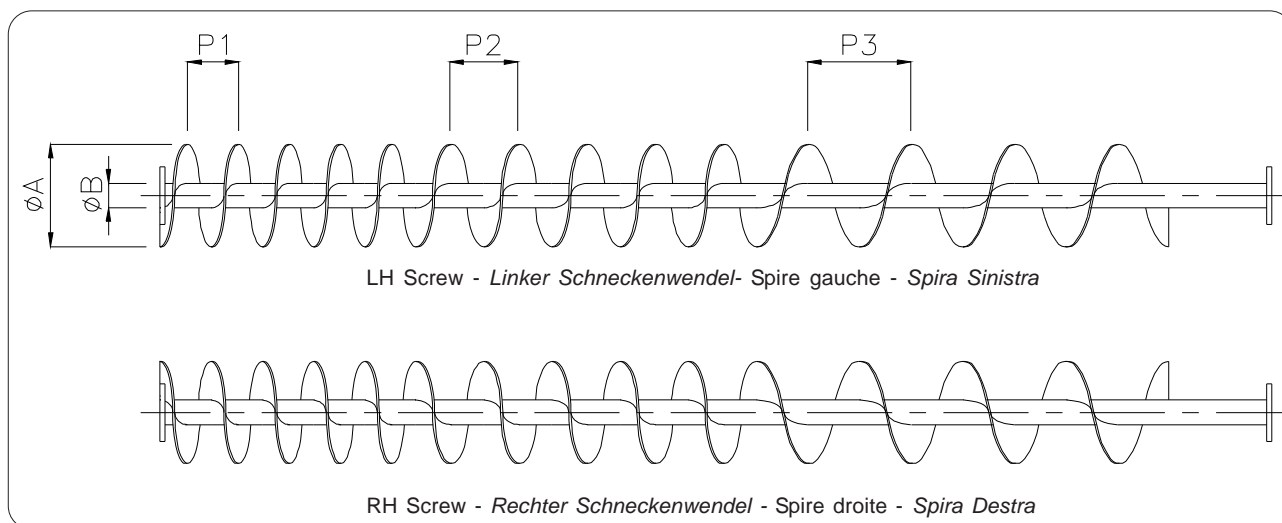

Ø	Code	ø A	ø B	P1 (1/2)	P2 (2/3)	P3 (1/1)	Weight - Gewichte Poids - Peso kg/m
150	XE..015.....	150	60	75	100	150	12.7
200	XE..020.....	200	60	100	133	200	15.5
	XE..020.....		114				23.3
250	XE..025.....	250	60	125	167	250	17.5
	XE..025.....		114				25.5
300	XE..030.....	300	114	150	200	300	27.5
	XE..030.....		168				23
350	XE..035.....	350	114	175	233	350	29.5
	XE..035.....		168				25.5
400	XE..040.....	400	114	200	266	400	34
	XE..040.....		168				29.5
500	XE..050.....	500	114	250	333	500	38.5
	XE..050.....		168				34.5
600	XE..060.....	600	168	300	400	600	58.5
	XE..060.....		219				50

Note

The pitch values in the Table are approximate: their presence and extension depends on the product to be extracted and the length of the inlet opening.

The pitch refers to a screw with flight pitch 1/1.

Anmerkung

Die Steigungen der Tabelle sind unverbindlich. Das Vorhandensein oder Nichtvorhandensein und ihre Ausdehnung hängt vom auszutragenden Produkt und der Länge des Einlaufs ab.

Das Gewicht ist auf die Schraubenwendel mit Steigung 1/1 bezogen.

Remarque

Les pas de la table sont indicatifs, leur présence ou pas et leur extension dépendent du produit à extraire et de la longueur de l'ouverture de l'entrée de chargement.

Le poids se réfère à la spire avec hélice ayant un pas 1/1.

Nota

I passi in tabella sono indicativi, la loro presenza o meno e la loro estensione dipendono dal prodotto da estrarre e dalla lunghezza dell'apertura di carico.

Il peso è riferito alla spira con elica avente passo 1/1.

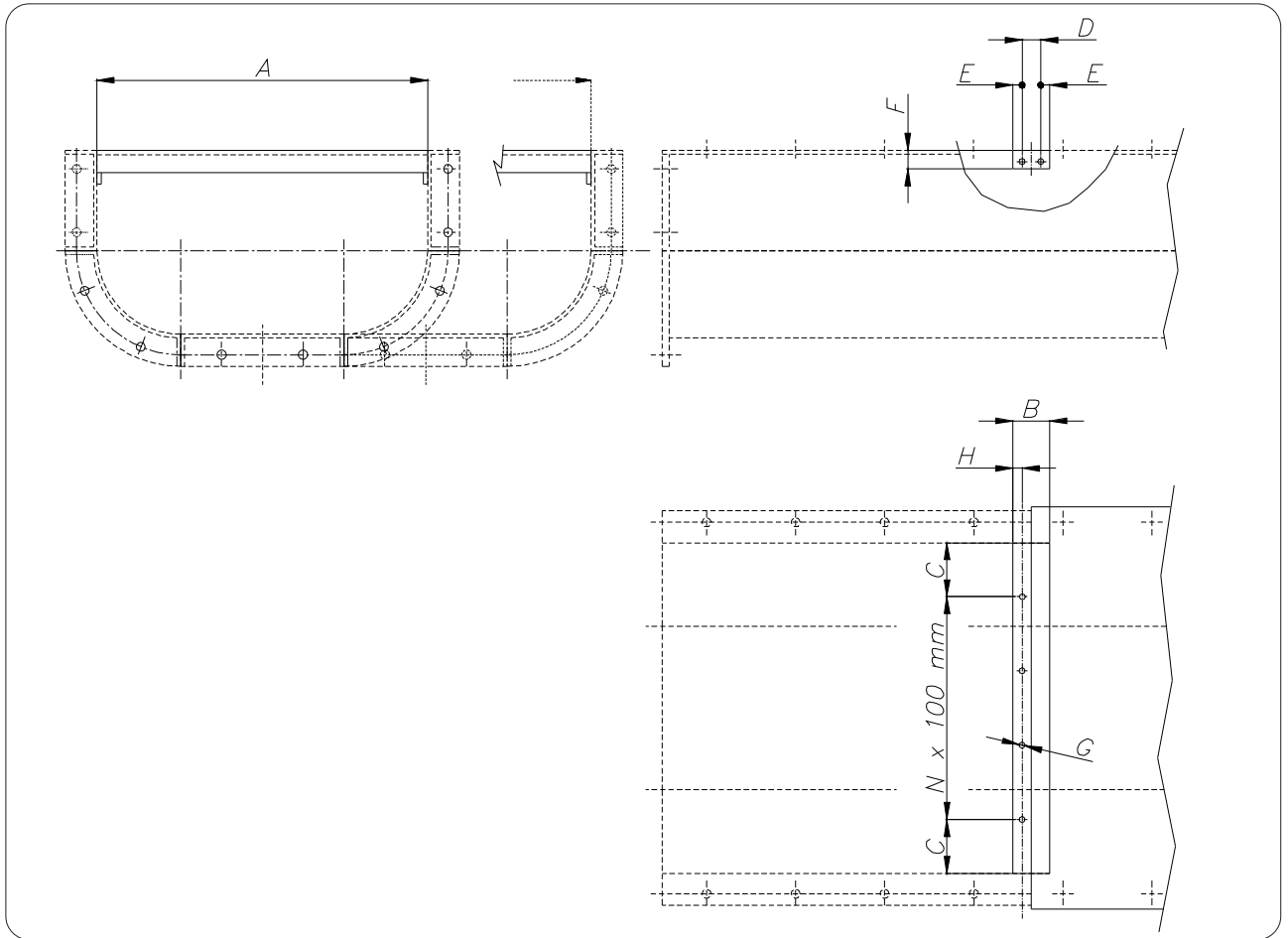

Ø	Code	A					N					C					B	D	E	F	G	H
		2EL	3EL	4EL	5EL	6EL	2EL	3EL	4EL	5EL	6EL	2EL	3EL	4EL	5EL	6EL						
150	XJQ.....	340	505	670	835	1000	2	4	5	7	8	70	52.5	85	67.5	100	100	50	25	45	12.5	25
200	XJQ.....	445	665	885	1105	1325	3	5	7	9	11	72.5	82.5	92.5	102.5	112.5	100	50	25	45	12.5	25
250	XJQ.....	545	815	1085	1355	1625	4	6	9	12	15	72.5	107.5	92.5	77.5	62.5	120	60	30	60	12.5	30
300	XJQ.....	645	965	1285	1605	1925	5	8	11	14	17	75.5	102.5	92.5	102.5	112.5	120	60	30	60	12.5	30
350	XJQ.....	755	1135	1515	1895	2275	6	10	14	18	21	77.5	67.5	57.5	47.5	87.5	120	60	30	60	12.5	30
400	XJQ.....	850	1275	1700	2125	2550	7	11	16	20	24	75	87.5	50	62.5	75	140	75	32.5	75	12.5	37.5
500	XJQ.....	1045	1565	2085	2605	3125	9	14	19	24	30	72.5	82.5	92.5	102.5	62.5	140	75	32.5	75	15.5	37.5
600	XJQ.....	1245	1865	2485	3105	3725	11	17	23	29	36	72.5	82.5	92.5	102.5	62.5	140	75	32.5	75	15.5	37.5

Type _____ X J Q 0 2 0 U 4 1

Ø of screws - *Wendelzahl*
 Ø Hélices - Ø *Eliche*

U = _____
 V = _____

Ø of screws - *Wendelzahl*
 Ø Hélices - Ø *Eliche*

Material - *Werkstoff*
 Material - *Materiale*

1= Fe
 2 = 304L st. st. - 1.4306 - Inox 304L - Aisi 304L
 3 = 316L st. st. - 1.4404 - Inox 316L - Aisi 316L

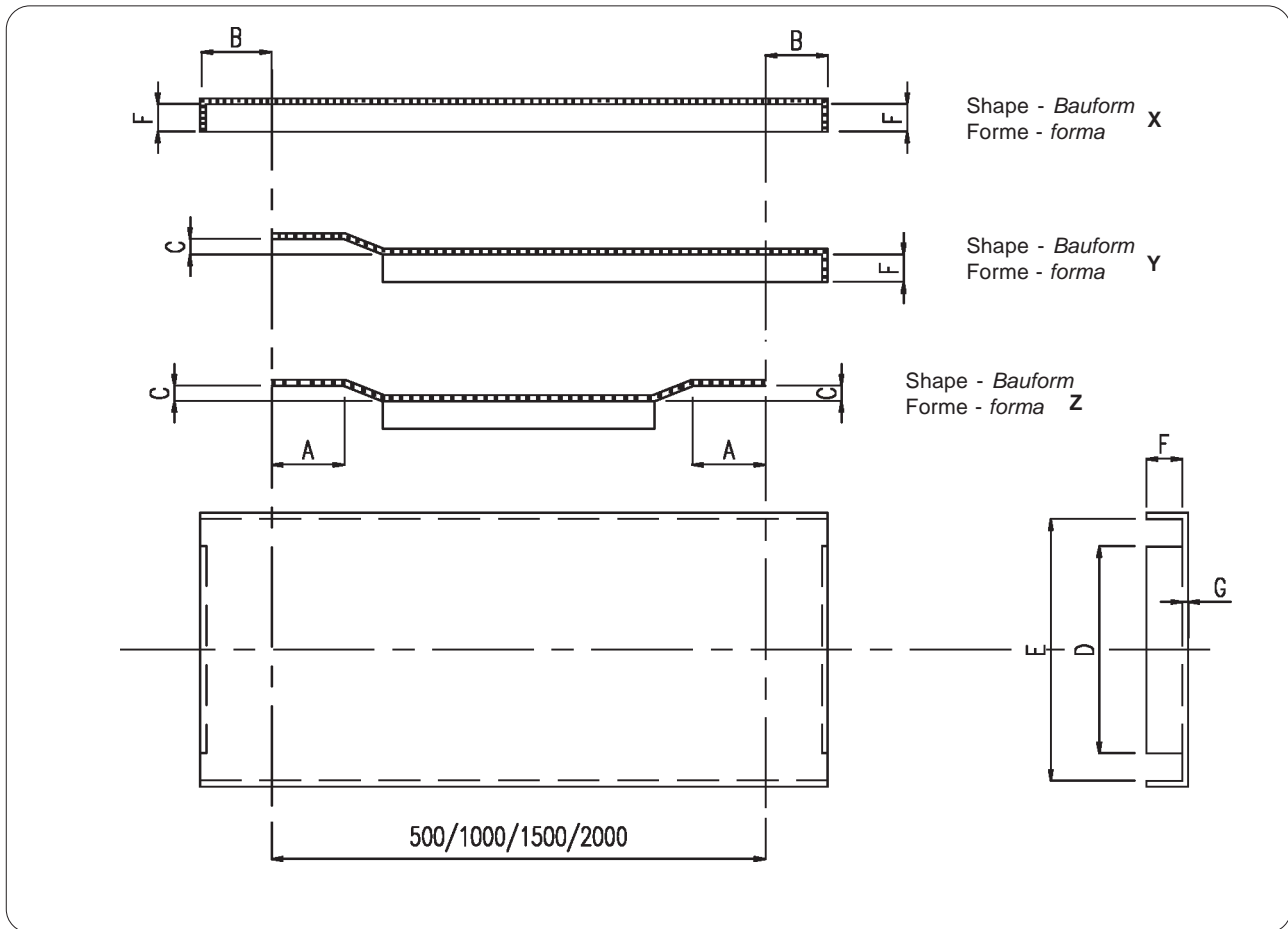

Ø U	Code	B	C	D					E					F	G	kg/m				
				2 EL	3 EL	4 EL	5 EL	6 EL	2 EL	3 EL	4 EL	5 EL	6 EL			2 EL	3 EL	4 EL	5 EL	6 EL
150	XFCC015....1	50	3.5	338	503	668	833	998	436	601	766	931	1096	15	2	7.3	9.9	12.5	15.1	17.7
200	XFCC020....1	50	3.5	440	660	880	1100	1320	538	758	978	1198	1418	15	2	8.9	12.3	15.7	19.1	22.6
250	XFCC025....1	60	3.5	540	810	1080	1350	1620	642	912	1182	1452	1722	15	2	10.5	14.5	18.6	22.7	26.7
300	XFCC030....1	60	4	640	960	1280	1600	1920	762	1082	1402	1722	2042	15	2	15.3	21.6	27.8	34	40.3
350	XFCC035....1	60	4	750	1050	1350	1650	1950	872	1252	1632	2012	2392	15	2	17.6	24.6	31.6	38.6	45.7
400	XFCC040....1	70	4	845	1270	1695	2120	2545	967	1392	1817	2242	2667	15	2	19.4	27.6	35.8	44	52
500	XFCC050....1	70	4	1040	1560	2080	2600	3120	1182	1702	2222	2742	3262	15	2	23.6	33.7	44	54	64
600	XFCC060....1	70	4	1240	1860	2480	3100	3720	1382	2002	2622	3242	3862	15	2	27.5	39.6	51.7	64	76

BOLTED LOCK - SCHRAUBVERSCHLUSS - FERMETURE BOULONNEE - CHIUSURA A BULLONI

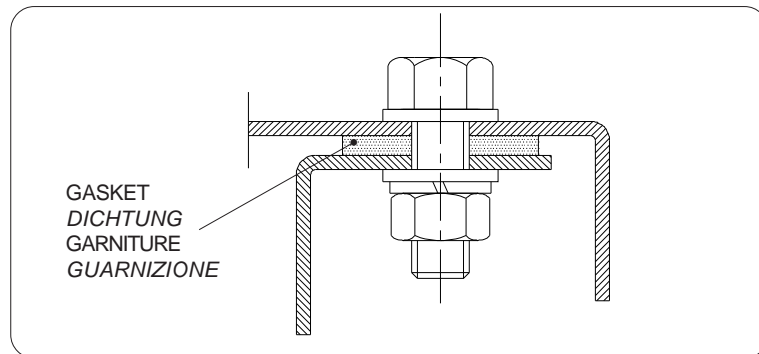

Code	Type
XKH10.	M10 X 25

GASKET - DICHTUNG - GARNITURE - GUARNIZIONE

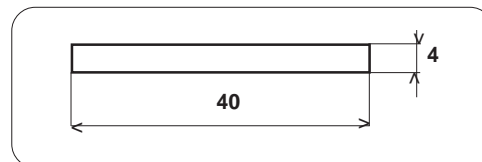

Code	Colour - Farbe Couleur - Colore	Type
2510TE0186	WHITE - WEISS BLANC - BIANCO	EPDMRE42

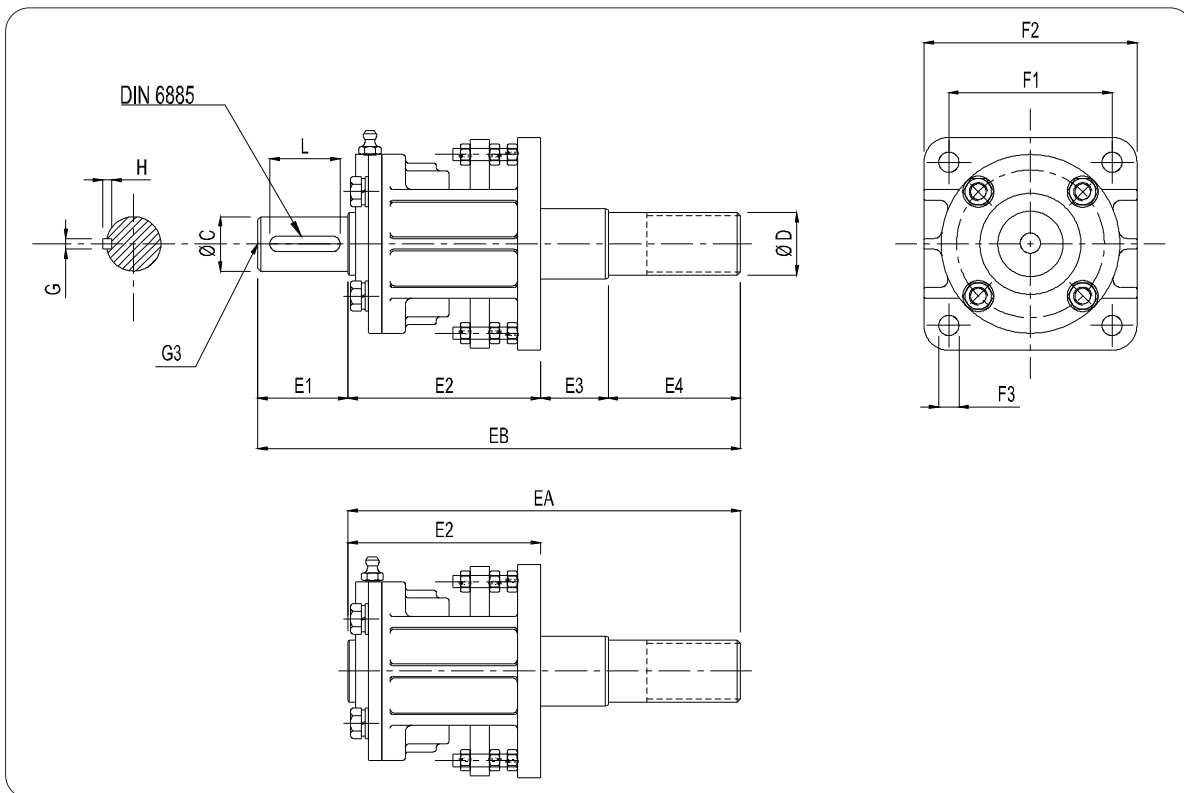

Code	Ø C UNI 6397	D DIN 5482	EA	EB	E1	E2	E3	E4	F1	F2	F3	L	G3	GxHxL DIN 6885	kg
XSP025 . .1	25	28 x 25	203	245	42	114	24	65	92	117	11	35	M10	8x7x36	5
XSP035 . .1	35	40 x 36	252.5	310.5	58	124	43.5	85	105	137	13	35	M10	10x8x50	6.5
XSP045 . .1	45	48 x 44	271.5	353.5	82	143	43.5	85	130	162	13	45	M12	14x9x70	14
XSP055 . .1	55	60 x 55	304.5	386.5	82	151	43.5	110	149	210	18	55	M12	16x10x70	22
XSP065 . .1	65	75 x 69	337.5	442.5	105	162	45.5	130	171	240	18	65	M16	18x11x90	32
XSP080 . .1	80	90 x 84	410	540	130	180	60	170	198	250	22	82	M20	20x12x110	55

CodeA..B..E..	kg Grease Fett Grasse Grasso	Seal Wellendichtung Etanchéité Tenuta
	Bearing Wälzlager Roulement Cuscinetto	Bearings Wälzlager Roulements Cusciniti	Bearing Wälzlager Roulement Cuscinetto		
XSP025 . .1	6206	6206 - 51106	22206CC	0.04	XUC 035
XSP035 . .1	6208	6208 - 51108	22208CC	0.06	XUC 045
XSP045 . .1	6210	6210 - 51110	22210CC	0.1	XUC 055
XSP055 . .1	6212	6212 - 51112	22212CC	0.14	XUC 070
XSP065 . .1	6214	6214 - 51114	22214CC	0.2	XUC 080
XSP080 . .1	6218	6218 - 51118	22218CC	0.4	XUC 100

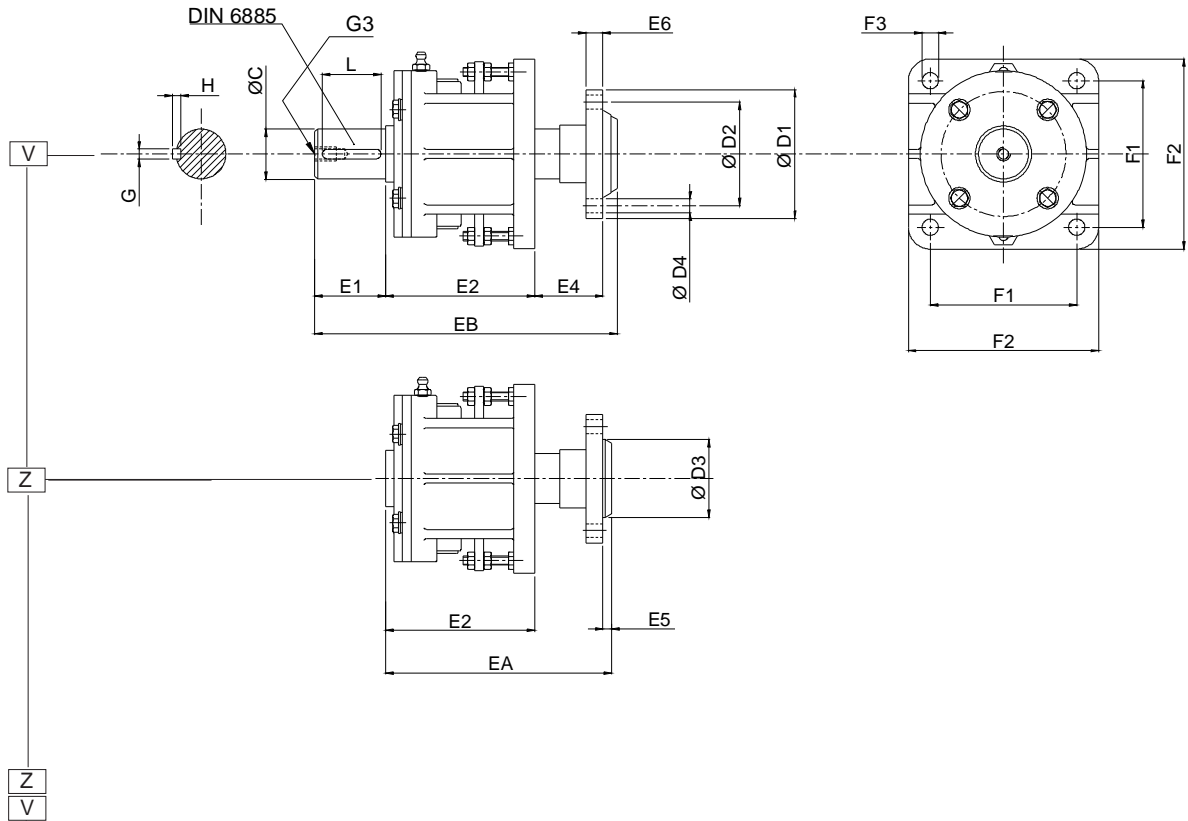

Code	Ø C UNI 6397	Ø D1	Ø D2	Ø D3	D4		EA	EB	E1	E2	E4	E5	E6	F1	F2	F3	GxHxL DIN 6885	G3	kg
					Ø	n													
XSR025 . . 1	25	95	70	50	10.5	4	162	204	42	114	55.5	2.5	10	92	117	11	8x7x36	M10	6
XSR035 . . 1	35	110	85	65	12.5	4	199.5	257.5	58	124	72.5	5.5	12	105	137	13	10x8x50	M10	8
XSR045 . . 1	45	130	100	78	16.5	4	226.5	308.5	82	143	84	9.5	12	130	162	13	14x9x70	M12	16
XSR055 . . 1	55	155	125	105	16.5	6	250.5	332.5	82	151	106.5	17.5	20	149	210	18	16x10x70	M12	26
XSR065 . . 1	65	155	125	105	16.5	6	263.5	368.5	105	162	106.5	17.5	20	171	240	18	18x11x90	M16	35
XSR080 . . 1	80	200	160	135	21	6	312	442	130	180	129	28	22	198	250	22	22x14x110	M20	62
XSR100 . . 1	100	235	190	160	25	6	396	561	165	230	135	38	25	266	340	30	28x16x140	M24	107

CodeA..B..E..	kg Grease Fett Grasso	Seal Wellendichtung Etanchéité Tenuta
	Bearing Wälzlager Roulement Cuscinetto	Bearings Wälzlager Roulements Cuscinetti	Bearing Wälzlager Roulement Cuscinetto		
XSR025 . . 1	6206	6206 - 51106	22206CC	0.04	XUC 035
XSR035 . . 1	6208	6208 - 51108	22208CC	0.06	XUC 045
XSR045 . . 1	6210	6210 - 51110	22210CC	0.1	XUC 055
XSR055 . . 1	6212	6212 - 51112	22212CC	0.14	XUC 070
XSR065 . . 1	6214	6214 - 51114	22214CC	0.2	XUC 080
XSR080 . . 1	6218	6218 - 51118	22218CC	0.4	XUC 100
XSR100 . . 1	6222	6222 - 51122	22222CC	0.6	XUC 115

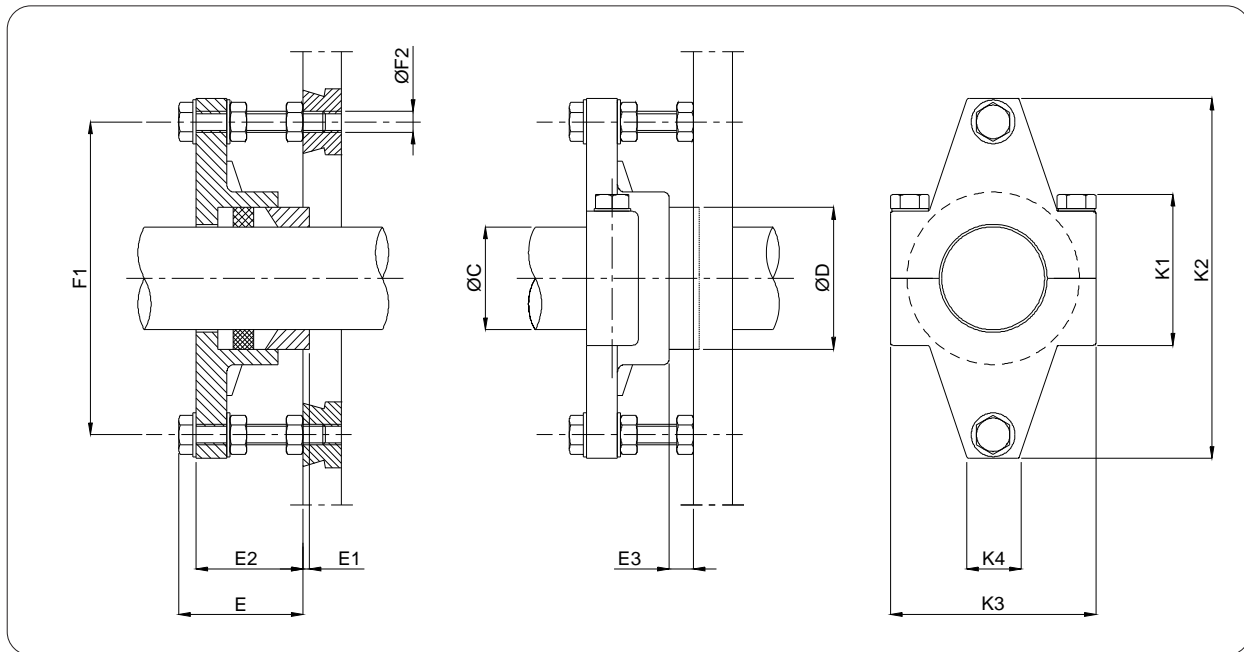

Packing - Packung - Garniture à tresse - Baderna

B = standard:graphitized - *standard:graphitiert* - *std:graphitée* - *std grafitata*
 C = teflonized - *tefloniert* - *teflonée* - *teflonata*
 D = fiberglass - *Fiberglas* - *fibre de verre* - *filato di vetro*

Code	Ø C	Ø D	E	E1	E2	E3	F1	Ø F2	K1	K2	K3	K4	kg	For Für Pour Per
XUC030 . 1	030	45	48	2	28	12	99	M8	20	120	70	50	0.5	S21
XUC035 . 1	035	50	48	2	28	12	99	M8	20	120	70	50	0.65	XS.025
XUC040 . 1	040	55	48	2	28	12	121.6	M8	20	140	80	60	0.75	S23
XUC045 . 1	045	60	48	2	28	12	121.6	M8	20	140	80	60	0.8	XS.035
XUC050 . 1	050	70	60	3	36	14	141.4	M10	30	164	100	70	1.2	S25
XUC055 . 1	055	75	60	3	36	14	141.5	M10	30	164	100	70	1.5	XS.045
XUC060 . 1	060	80	60	3	36	14	183.4	M10	30	210	120	70	1.8	S27
XUC070 . 1	070	90	60	3	36	14	183.4	M10	30	210	120	70	2	XS.055
XUC080 . 1	080	100	62	3	36	14	210.7	M12	35	240	140	70	2.5	XS.065
XUC100 . 1	100	120	80	3	36	18	210.7	M12	40	244	155	80	3	XS.080
XUC115 . 1	115	140	85	4	50	18	219	M16	45	344	180	110	6.5	XS.100

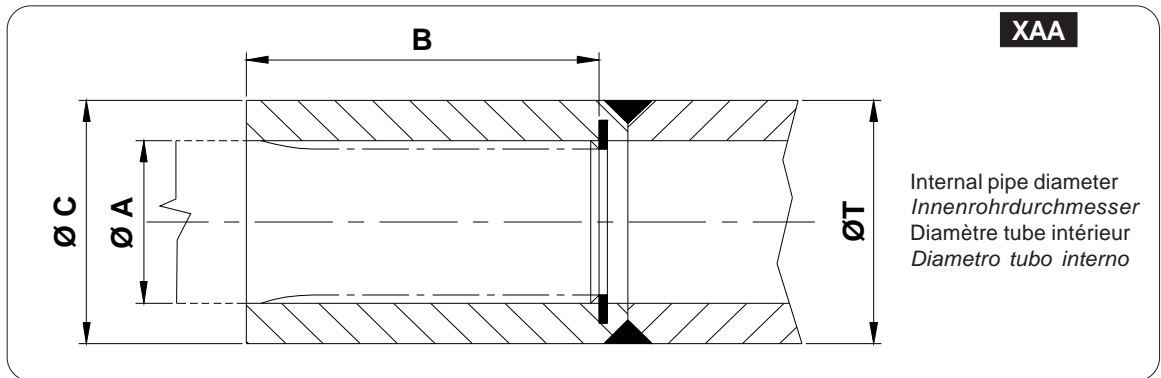

040 = Ø 150 - 200 - 250
048 = Ø 150 - 200 - 250
060 = Ø 300 - 350 - 400 - 500
075 = Ø 500
090 = Ø 600

060 = Ø 150 - 200 - 250
114 = Ø 300 - 350 - 400 - 500
168 = Ø 600

X A A T 1

Code	Ø A DIN 5482	B	Ø C	Ø T	kg
XAA040T0601	40 x 36	92	60	60	1.15
XAA048T0601	48 x 44	92	60	60	1
XAA060T1141	60 x 55	140	114	114	8.2
XAA075T1141	75 x 69	140	114	114	6.75
XAA090T1681	90 x 84	180	168	168	23

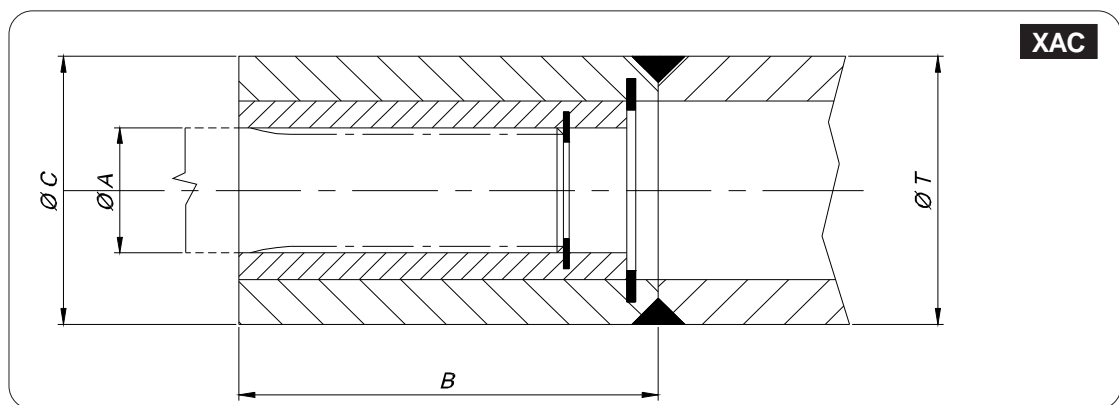

X A C T 1

Code	Ø A DIN 5482	B	Ø C	Ø T	kg
XAC028T0601	28 x 25	92	60	60	1.5
XAC040T1141	40 x 36	140	114	114	9.2
XAC048T1141	48 x 44	140	114	114	9

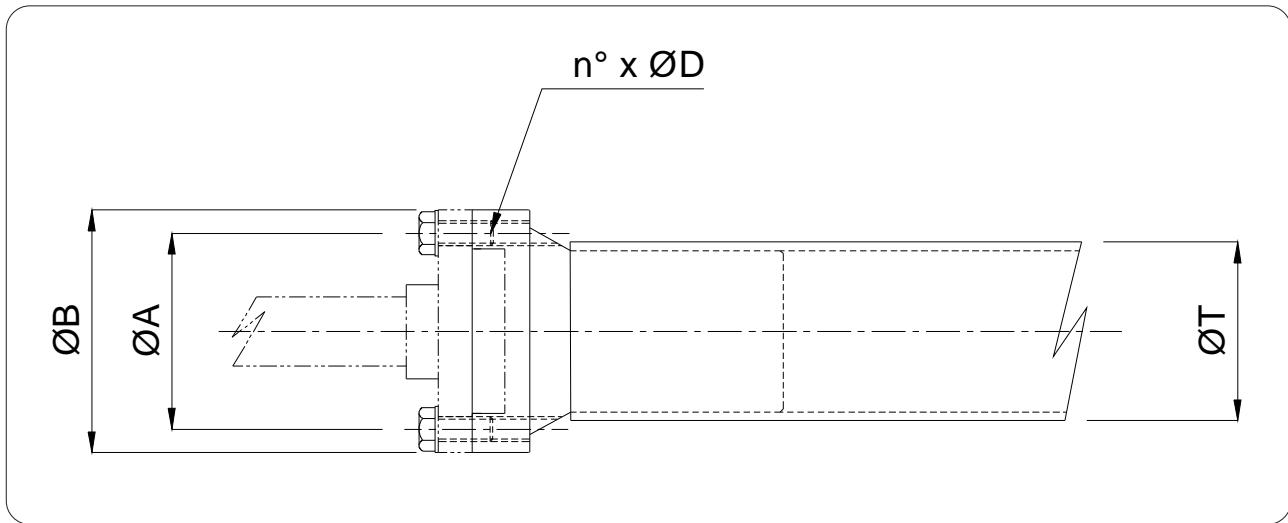

Ø A	Ø B	D	n°	Ø T					
				060		114		168	
				Code	kg	Code	kg	Code	kg
085	110	M12	4	XAV085T0601	3.1	/		/	
100	130	M16	4	XAV100T0601	4.5	/		/	
	155	M16	4	/		XAV100T1141	15.4	/	
125	155	M16	6	/		XAV125T1141	13.2	/	
160	200	M20	6	/		XAV160T1141	18	XAV160T1681	33
190	235	M24	6	/		XAV190T1141	23.5	XAV190T1681	36.5

080 = 0.75 kW
090 = 1.1 - 1.5 kW
100 = 2.2 - 3 kW
112 = 4.0 kW

4 = splined / Vielkeil
cannelée / calettata
6 = flanged / Flansch
bride / flangiata

090 = 1.1 - 1.5 kW
100 = 2.2 - 3 kW
112 = 4 kW
132 = 5.5 - 7.5 - 9.2 kW

4 = splined / Vielkeil
cannelée / calettata
6 = flanged / Flansch
à bride / flangiata

S 2 1 [] [] [] [] [] [] B 4 1

ratio - see catalogue
Unters. - Siehe Katalog
rapp. - voir catalogue
rapp. - vedi catalogo

S 2 3 [] [] [] [] [] [] B 4 3

ratio - see catalogue
Unters. - Siehe Katalog
rapp. - voir catalogue
rapp. - vedi catalogo

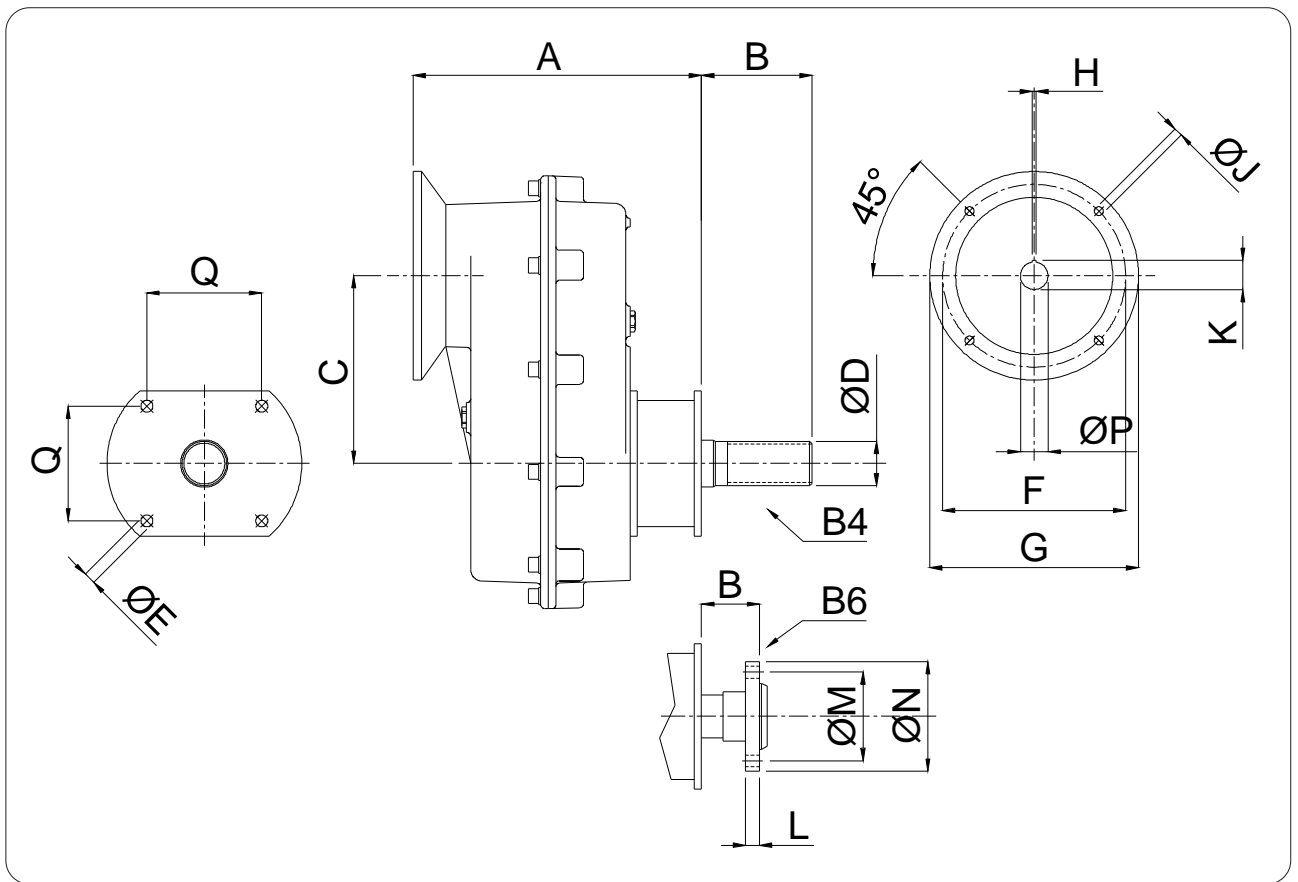

100 = 2.2 - 3 kW
112 = 4 kW
132 = 5.5 - 7.5 - 9.2 kW
160 = 11 - 15 kW
180 = 18.5 - 22 kW

4 = splined / Vielkeil
cannelée / calettata
6 = flanged / Flansch
à bride / flangiata

112 = 4 kW
132 = 5.5 - 7.5 - 9.2 kW
160 = 11 - 15 kW
180 = 18.5 - 22 kW
200 = 30 - 37 kW

4 = splined / Vielkeil
cannelée / calettata
6 = flanged / Flansch
à bride / flangiata

S 2 5 [] [] [] [] [] [] B 4 5

ratio - see catalogue
Unters. - Siehe Katalog
rapp. - voir catalogue
rapp. - vedi catalogo

S 2 7 [] [] [] [] [] [] B 4 7

ratio - see catalogue
Unters. - Siehe Katalog
rapp. - voir catalogue
rapp. - vedi catalogo

S21

Motor size Motorgröße Taille moteur Gr. motore	A	B		C	DIN 5482 ø D	ø E	F	G	H	ø J	K	L	ø M	ø N	ø P	Q	kg
		B 4	B 6														
080	225	89	55.5	143	28 x 25	13	165	200	6	12	21.5	8	70	95	19	105	30
090	225	89	55.5	143	28 x 25	13	165	200	6	12	21	8	70	95	24	105	30
100	235	89	55.5	143	28 x 25	13	215	250	8	15	31	8	70	95	28	105	32
112	235	89	55.5	143	28 x 25	13	215	250	8	15	31	8	70	95	28	105	32

S23

Motor size Motorgröße Taille moteur Gr. motore	A	B		C	DIN 5482 ø D	ø E	F	G	H	ø J	K	L	ø M	ø N	ø P	Q	kg
		B 4	B 6														
090	276	128.5	72.5	143	40 x 36	13	165	200	8	12	27	10	85	110	24	130	45
100	286	128.5	72.5	143	40 x 36	13	215	250	8	15	31	10	85	110	28	130	46
112	286	128.5	72.5	143	40 x 36	13	215	250	8	15	31	10	85	110	28	130	46
132	284	128.5	72.5	143	40 x 36	13	265	300	10	15	41	10	85	110	28	130	48

S25

Motor size Motorgröße Taille moteur Gr. motore	A	B		C	DIN 5482 ø D	ø E	F	G	H	ø J	K	L	ø M	ø N	ø P	Q	kg
		B 4	B 6														
100	315	128.5	84	180	48x44	17	215	250	8	15	31	12	125	155	31	149	75
112																	
132	330	128.5	84	180	48x44	17	265	300	10	15	41	12	125	155	41	149	78
160	352	128.5	84	180	48x44	17	300	350	12	19	45	12	125	155	45	149	80
180	352	128.5	84	180	48x44	17	300	350	14	19	51.5	12	125	155	51.5	149	

S27

Motor size Motorgröße Taille moteur Gr. motore	A	B		C	DIN 5482 ø D	ø E	F	G	H	ø J	K	L	ø M	ø N	ø P	Q	kg
		B4	B6														
112	350	153.5	106.5	225	60x55	22	215	250	8	15	31	15	125	155	28	198	138
132	365	153.5	106.5	225	60x55	22	265	300	10	15	41	15	125	155	38	198	140
160	387	153.5	106.5	225	60x55	22	300	350	12	19	45	15	125	155	42	198	146
180	387	153.5	106.5	225	60x55	22	300	350	14	19	51.5	15	125	155	48	198	146
200	392	153.5	106.5	225	60x55	22	350	400	16	19	59	15	125	155	55	198	151

N.B.: When mounted on conveyor, reducer painted Gentian Blue RAL 5010. As spare part painted with primer.

N.B.: Wenn Getriebe auf Schnecke montiert, Getriebe in enzianblau RAL 5010. Als Ersatzteil mit Grundanstrich.

N.B.: Monté sur la vis, peint en Bleu Gentiane RAL 5010. Comme pièce de rechange antirouille.

N.B.: Montato sulla coclea è verniciato in Blu Genziana RAL 5010, come ricambio è verniciato in antiruggine.

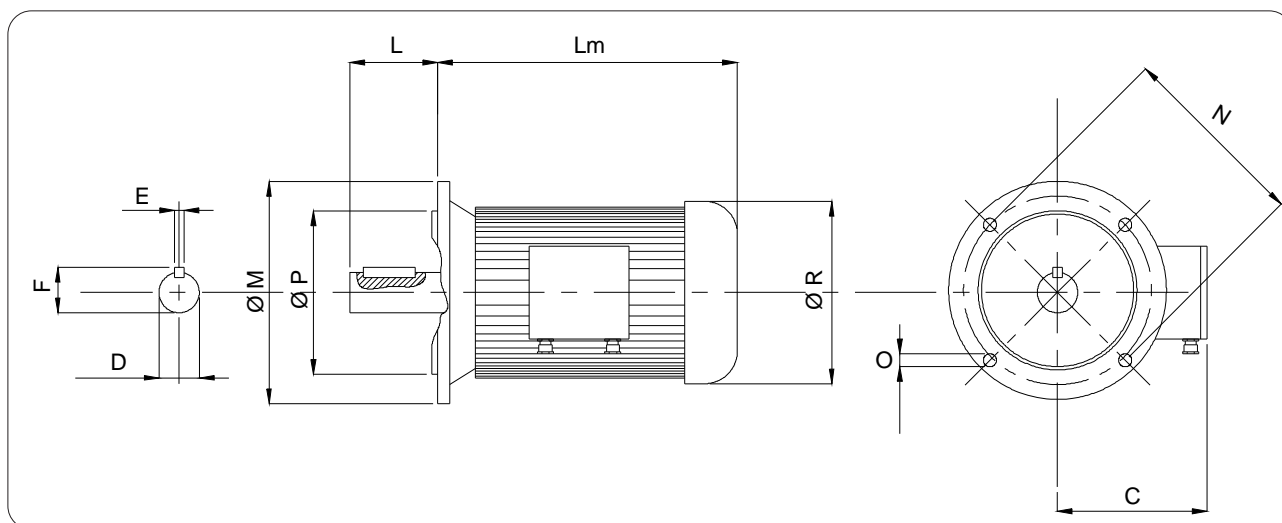

kW	Mot.	Code	C	D	E	F	L	Lm*	M	N	O	Holes n°	P	Q	R	KK mm	n°	kg
			mm										mm					
1.1	90 S	MT0900S04145	155	24	8	27	50	248	200	165	12.5	4	130	3.5	180	M25x1.5	1	25
1.5	90 L	MT0900L04145	155	24	8	27	50	273	200	165	12.5	4	130	3.5	180	M25x1.5	1	26
2.2	100 LR	MT100LR04145	180	28	8	31	60	306	250	215	15	4	180	4	218	M25x1.5	2	34
3	100 LH	MT100LH04145	180	28	8	31	60	306	250	215	15	4	180	4	218	M25x1.5	2	35
4	112 M	MT1120M04145	190	28	8	31	60	334	250	215	15	4	180	4	218	M32x1.5	2	44
3 - 1.5	112 M	MT1120M48A45	190	28	8	31	60	334	250	215	15	4	180	4	218	M32x1.5	2	47
5.5	132 S	MT1320S04145	210	38	10	41	80	371	300	265	15	4	230	4	258	M32x1.5	2	65
3.3 - 2.2	132S	MT1320S48A45	210	38	10	41	80	371	300	265	15	4	230	4	258	M32x1.5	2	65
7.5	132 M	MT1320M04145	210	38	10	41	80	409	300	265	15	4	230	4	258	M32x1.5	2	79
4.4 - 3	132 M	MT1320M48A45	210	38	10	41	80	409	300	265	15	4	230	4	258	M32x1.5	2	79
9.2	132 ML	MT1320L04145	210	38	10	41	80	409	300	265	15	4	230	4	258	M32x1.5	2	87
11	160 M	MT1600M04245	255	42	12	45	110	485	350	300	19	4	250	5	300	M40x1.5	2	118
6 - 4.5	160 MA	MT160MA48A45	255	42	12	45	110	485	350	300	19	4	250	5	300	M40x1.5	2	118
8.5 - 6	160 MB	MT160MB48A45	255	42	12	45	110	485	350	300	19	4	250	5	300	M40x1.5	2	118
15	160 L	MT1600L04245	255	42	12	45	110	529	350	300	19	4	250	5	300	M40x1.5	2	147
10 - 7.5	160 L	MT1600L48A45	255	42	12	45	110	529	350	300	19	4	250	5	300	M40x1.5	2	147
18.5	180 M	MT1800M04245	285	48	14	51.5	110	543	350	300	19	4	250	5	340	M40x1.5	2	173
22.0	180 L	MT1800L04245	285	48	14	51.5	110	585	350	300	19	4	250	5	340	M40x1.5	2	220
15 - 10	180 L	MT1800L48A45	285	48	14	51.5	110	585	350	300	19	4	250	5	340	M40x1.5	2	220

Cable gland is made of plastic. Junction on left side of motor seen standing behind fan. Cable gland below.

*With different motor makes, a tolerance of ± 50 mm should be allowed.

N.B.: Double speed motors (4-8 poles) must be started at low speed and subsequently automatically switched to high speed.

N.B.: When mounted on feeder motor painted Gentian Blue RAL 5010. As spare part only primer painted.

PG - Verschraubungen aus Kunststoff. Klemmenkasten auf der linken Seite von Lüfterhaube aus gesehen. Kabeleintritte an der Unterseite des Klemmenkastens.

*Je nach Fabrikat sind Toleranzen von ± 50 mm möglich.

N.B.: Polumschaltbare Motoren (4-8 polig) müssen in der kleinen Drehzahl anlaufen und anschliessend automatisch auf die hohe Drehzahl umgeschaltet werden.

N.B.: Wenn Getriebe auf Schnecke montiert ist, Lackierung = ezian-blau RAL 5010. Als Ersatzteil nur mit Grundanstrich.

Presse-câbles en plastique.

Boîte à bornes sur la côté gauche du moteur (vu du carter).

*Avec des marques diverses des tolérances de ± 50 mm sont possibles.

N.B.: Les moteurs à double polarité (4-8 poles) doivent être démarrés dans la vitesse basse et successivement commutés automatiquement à la vitesse haute.

N.B.: Monté sur la vis les moteurs sont peints en Bleu Gentiane RAL 5010. Comme pièce de rechange en antirouille.

I pressacavi sono in plastica.

La morsettiera si trova sul lato sinistro del motore (visto dal carter).

*Con marche diverse sono possibili tolleranze di ± 50 mm.

N.B.: I motori a doppia polarità (4-8 poli) devono essere avviati nella bassa velocità e devono essere successivamente commutati in automatico all'alta velocità.

N.B.: Montato sulla coclea è verniciato in Blu Genziana RAL 5010; come ricambio è verniciato in antiruggine.

The motors listed in the table are WAM® models manufactured according to IEC as well as DIN standards as far as junction box connections are concerned. This means other electric motor makes can be used providing they conform to the above mentioned standards without having to change the gear reducer.

CONFORMITY

WAM® motors are constructed in accordance with:

- Standards 89/336/EEC (EMC Directive).
- Low Voltage Directive 73/ 23/EEC.

Technical features
For all:

- Construction form B5 flanged
- Isolation class F
- Motor protection IP 55
- Terminal protection IP 55

4-poles motors

- Rotation speed ~ 1450rpm
- Voltage 230/400V to 9.2 kW (inclusive)
- Voltage 400/690V 11 kW to 22 kW.
- Frequency 50 Hz

4/8-poles motors

- single Dahlander type winding
- rotation speed ~ 1450/ 730rpm
- single voltage 400V
- frequency 50 Hz

Operating conditions

WAM® motors can withstand a humidity content of 90% and can operate at environmental temperatures varying from -10° to +40°C.

If motors with special technical characteristics are required (voltage, cycles, double speed etc.) please contact a WAM® sales office.

For further details and characteristics see electric motor catalogue WA.052MT

Die in der Tabelle aufgeführten Elektro-Flanschmotoren, Fabrikat WAM®, entsprechen der europäischen IEC-Norm sowie der DIN, was die Klemmenverbindungen betrifft. Dies ermöglicht es, wahlweise Normmotoren eines anderen Fabrikats einzusetzen, ohne dabei die Getriebeeinheit austauschen zu müssen. Es muss allerdings beachtet werden, dass WAM-Motoren als Ergebnis langjähriger Praxiserfahrungen die beste Garantie für einen problemfreien Betrieb in den unterschiedlichsten Anwendungsbereichen bieten.

KONFORMITÄT

Die WAM® Motoren entsprechen den folgenden Normen:

- EMV-Richtlinie 89/336/EWG
- Niederspannungs-Richtlinie 73/ 23/EWG.

Technische Eigenschaften
Für alle:

- Bauform B5 mit Flansch
- Isolierstoffklasse F
- Motorschutzart IP 55
- Schutzart Klemmenleiste IP 55

4-polige Motoren

- Drehzahl ~ 1450 min⁻¹
- Spannung 230/400V bis zu 9.2 kW einschließlich
- Spannung 400/690V von 11 kW bis 22 kW.
- Frequenz 50 Hz

4/8-polige Motoren

- Einzelwicklung Typ Dahlander
- Drehzahl ~ 1450/ 730 min⁻¹
- Einzelspannung 400V
- Frequenz 50 Hz

Betriebsbedingungen

Die WAM® Motoren ertragen einen Feuchtigkeitsgrad bis zu 90% und können bei einer Umgebungstemperatur zwischen -10° und +40°C arbeiten.

Sollte eine Sonderausführung in bezug auf Betriebsspannung, Frequenz, Polumschaltbarkeit etc. erforderlich sein, bitte mit dem zuständigen Verkaufsbüro Kontakt aufnehmen.

Für nähere Einzelheiten und technische Daten siehe Katalog der Elektromotoren WA.052MT.

Les moteurs listés dans le tableau sont de la marque WAM® et sont en conformité avec les normes européennes IEC et DIN en ce qui concerne les connexions dans la boîte à bornes. Ceci signifie que l'utilisateur a la possibilité d'utiliser des moteurs de quelconque marque, pourvu qu'ils soient conformes aux normes, sans devoir changer la tête motrice.

CONFORMITÉ

Les moteurs WAM® sont construits conformément:

- Aux normes 89/336/EEC (directive EMC).
- Aux directives basse tension 73/23/EEC.

Caractéristiques techniques
Pour tous:

- Forme de construction B5 à bride
- Classe d'isolation F
- Protection moteur IP 55
- Protection bornier IP 55

Moteurs à 4 pôles

- Vitesse de rotation ~ 1450 tr/mn
- Tension 230/400V jusqu'à 9.2 kW inclus
- Tension 400/690V de 11 kW à 22 kW.
- Fréquence 50 Hz

Moteurs à 4/8 pôles

- enroulement unique type Dahlander
- vitesse de rotation ~ 1450/ 730 tr/mn
- une seule tension 400V
- fréquence 50 Hz

Conditions de fonctionnement

Les moteurs WAM® peuvent résister à un taux d'humidité de 90% et ils peuvent travailler à une température ambiante qui varie de -10° à +40°C.

S'il était nécessaire d'utiliser un moteur avec des caractéristiques différentes (voltage, fréquence, polarité etc.) vous êtes priés de contacter notre bureau commerciaux.

Pour plus de détails et caractéristiques consulter le catalogue moteur électriques WA.052MT

I motori riportati nella tabella sono di marca WAM® e sono conformi alle norme europee IEC nonché alle norme DIN per quanto riguarda gli attacchi (pressacavi) nella morsettiera. Ciò significa che l'utilizzatore ha la possibilità di impiego di motori di qualsiasi marca, purchè siano a norme, senza dover cambiare testata motrice.

CONFORMITÀ

I motori WAM® sono costruiti secondo:

- Le norme 89/336/EEC (direttive EMC).
- Le direttive basso voltaggio 73/ 23/EEC.

Caratteristiche tecniche
Per tutti:

- Forma costruttiva B5 a flangia
- Classe isolamento F
- Protezione motore IP 55
- Protezione morsettiera IP 55

Motori a 4 poli

- Velocità di rotazione ~ 1450rpm
- Tensione 230/400V fino a 9.2 kW compresi
- Tensione 400/690V da 11 kW a 22 kW.
- Frequenza 50 Hz

Motori a 4/8 poli

- unico avvolgimento tipo Dahlander
- velocità di rotazione ~ 1450/ 730rpm
- unica tensione 400V
- frequenza 50 Hz

Condizioni di funzionamento

I motori WAM® possono resistere ad un tasso di umidità del 90% e possono lavorare ad una temperatura ambiente che varia da -10° a +40°C.

Qualora dovesse essere necessario l'impiego di un motore con caratteristiche diverse (voltaggio, frequenza, polarità, ecc.) siete pregati di contattare il ns. uff. tecnico commerciale.

Per ulteriori dettagli e caratteristiche tecniche vedi catalogo motori elettrici WA.052MT.

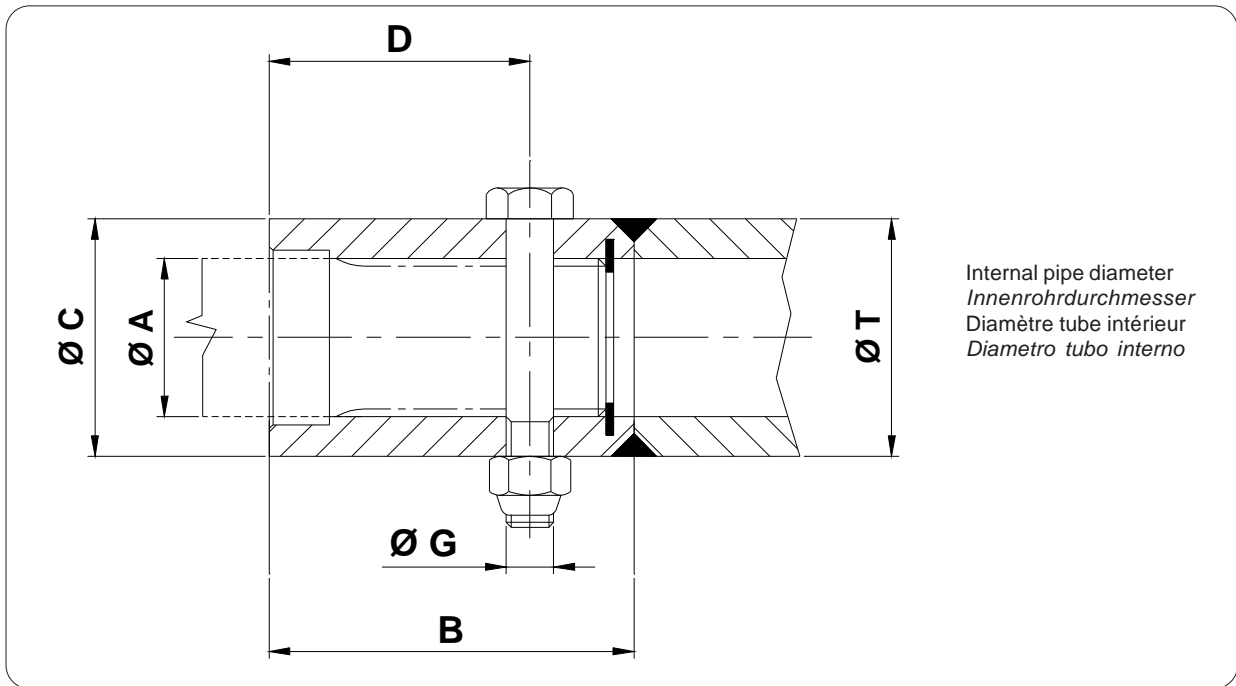

040 = Ø 168 - 219 - 273
 048 = Ø 168 - 219 - 273
 060 = Ø 323 - 406 - 457 - 558
 075 = Ø 558
 090 = Ø 660

042 = Ø 114
 048 = Ø 139
 060 = Ø 168 - 219 - 273
 114 = Ø 323 - 405 - 457 - 558
 168 = Ø 660

X A L T 1

Code	Ø A DIN 5482	B	Ø C	D	Ø G	Ø T	kg
XAL028T0421	28 x 25	65	42	35	M 10	42	0.45
XAL028T0481	28 x 25	65	48	35	M 10	48	0.65
XAL040T0601	40 x 36	92	60	35	M 12	60	1.15
XAL048T0601	48 x 44	92	60	45	M 16	60	1
XAL060T1141	60 x 55	140	114	55	M 16	114	8.2
XAL075T1141	75 x 59	140	114	65	M 20	114	6.75
XAL090T1681	90 x 84	180	168	82	M 24	168	23

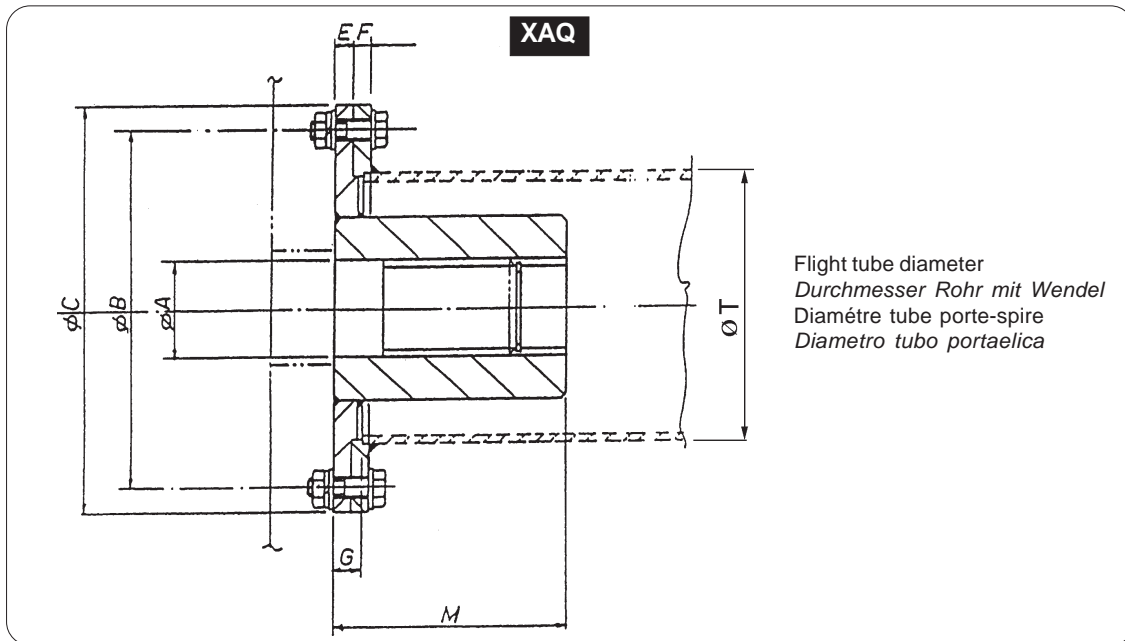

Code	ø A DIN 5482	ø B	ø C	E	F	G	M	ø T	kg
XAQ060T1681	60 x 55	220	250	11	11	18.5	140	168	13.8
XAQ075T1681	75 x 69	220	250	11	11	18.5	140	168	12.4
XAQ090T2191	90 x 14	250	275	11	11	18.5	180	219	15.4

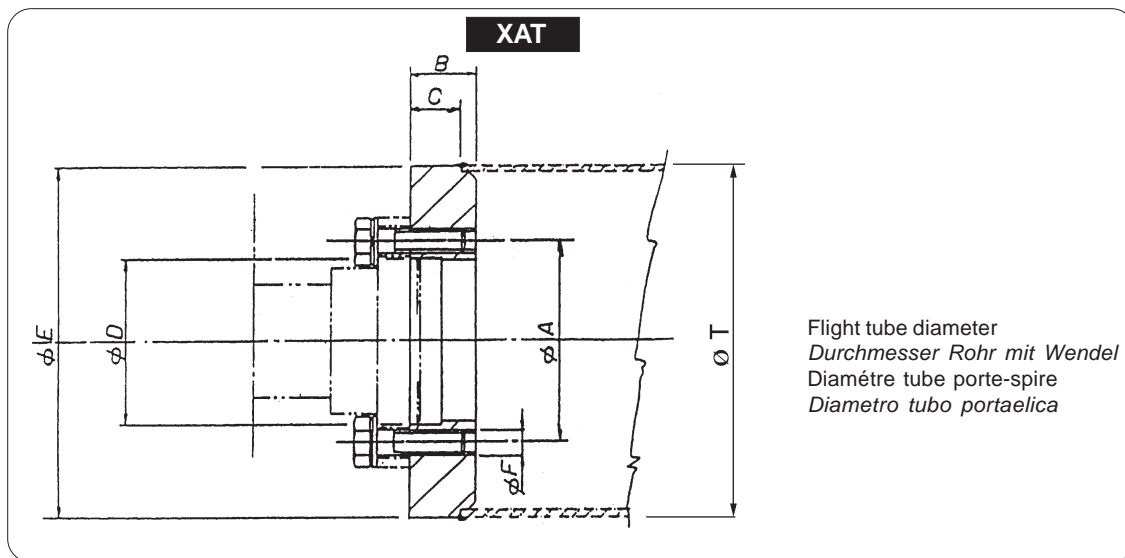

Code	ø A	B	C	ø D	ø E	F		ø T	kg
						ø	N°		
XAT125T1681	125	41	31	105	168	M 16	6	168	4.3
XAT150T2191	160	57	45	135	219	M 20	6	219	9.7
XAT190T2191	190	65	53	160	219	M 24	6	219	9

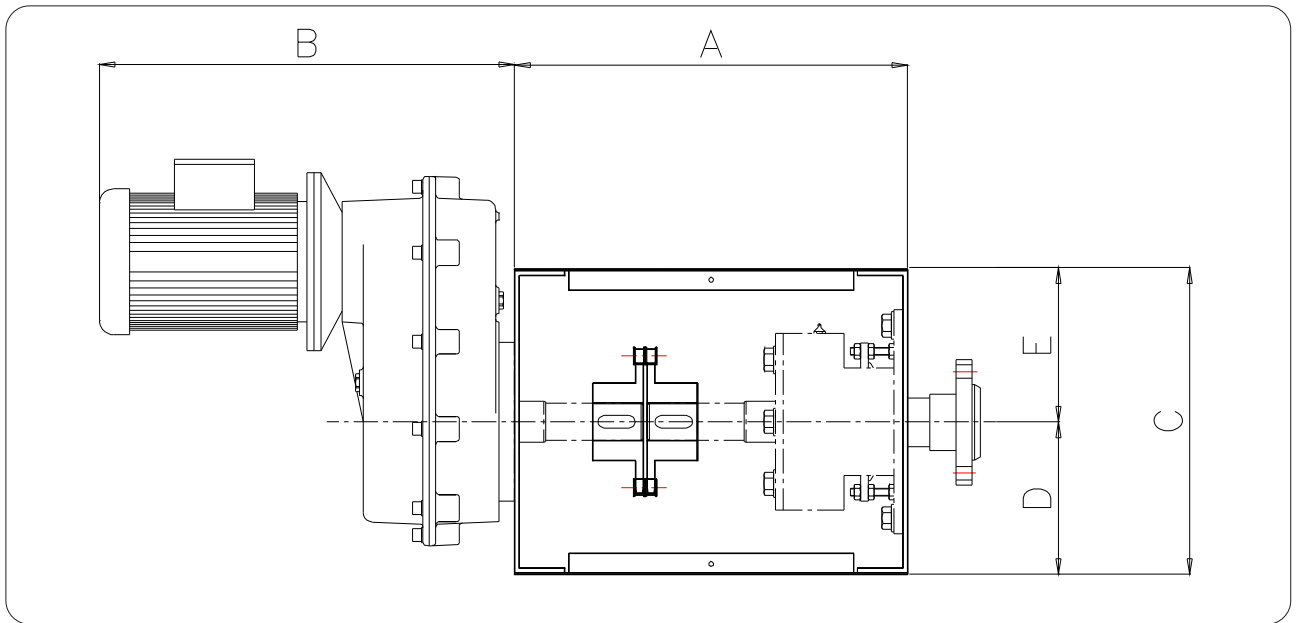

S 21							
kW	Ø	Ø	A	B	C	D	E
0.55	150	35	260	420	260	145	115
	200	35	260	420	320	185	135
0.75	150	35	260	430	260	145	115
1.1	150	35	260	450	260	145	115
1.5	150	35	260	460	260	145	115

S 23							
kW	Ø	Ø	A	B	C	D	E
0.75	200	35	280	430	320	185	135
	250	35	280	430	375	215	160
1.1	200	35	280	450	320	185	135
	250	35	280	460	375	215	160
1.5	150	35	280	460	260	145	115
	200	35	280	460	320	185	135
	250	35	280	460	375	215	160
2.2	200	35	280	470	260	145	115
3.0	200	35	280	490	260	145	115

S 25							
kW	Ø	Ø	A	B	C	D	E
1.1	300	55	390	600	440	245	195
1.5	300	55	390	610	440	245	195
	350	55	390	620	510	275	235
2.2	300	55	390	590	440	245	195
	350	55	390	620	510	275	235
4.0	400	55	390	590	575	305	270
	200	45	331	590	320	185	135
	300	55	390	600	440	245	195
	350	55	390	620	510	275	235
5.5	400	55	390	590	575	305	270
	250	35	280	500	375	215	160
	300	55	390	640	440	245	195
	350	55	390	640	510	275	235
7.5	400	55	390	640	575	305	270
	300	55	390	680	440	245	195
	350	55	390	680	510	275	235
11.0	400	55	390	680	575	305	270
	400	55	390	800	575	305	270

S 27							
kW	Ø	Ø	A	B	C	D	E
7.5	300	55	390	750	440	245	195
	350	55	390	750	510	275	235
	400	55	390	750	575	305	270
9.2	400	55	390	770	575	305	270
11.0	400	55	390	800	575	305	270

Note

The number of transmissions present in the MU must be defined in accordance with the Manufacturer.

Anmerkung

Die Zahl der Getriebe auf der MU ist mit dem Hersteller zu definieren.

Remarque

Le nombre des entraînements présents sur le MU doit être défini avec le Fabricant

Nota

Il numero delle trasmissioni presenti nel MU è da definire con il Costruttore

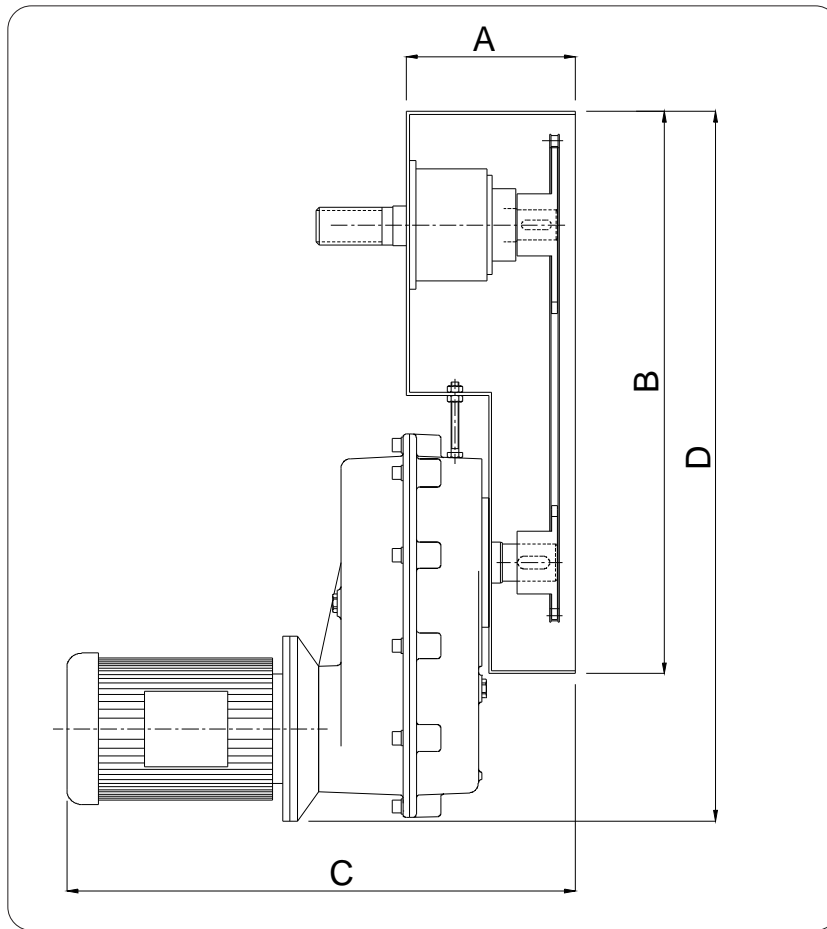

S 21				
kW	A	B	C	D
0.55	210	575	590	870
0.75	210	645	600	870

S 23				
kW	A	B	C	D
1.1	230	940	690	1100
1.5	230	940	690	1100

S 25				
kW	A	B	C	D
2.2	280	990	790	1250
3.0	280	990	790	1250

S 27				
kW	A	B	C	D
4.0	300	1105	880	1350
5.5	320	1105	950	1370
7.5	340	1105	990	1370

Note
The number of transmissions present in the MU must be defined in accordance with the Manufacturer.

Anmerkung
Die Zahl der Getriebe auf der MU ist mit dem Hersteller zu definieren.

Remarque
Le nombre des entraînements présents sur le MU doit être défini avec le Fabricant

Nota
Il numero delle trasmissioni presenti nel MU è da definire con il Costruttore

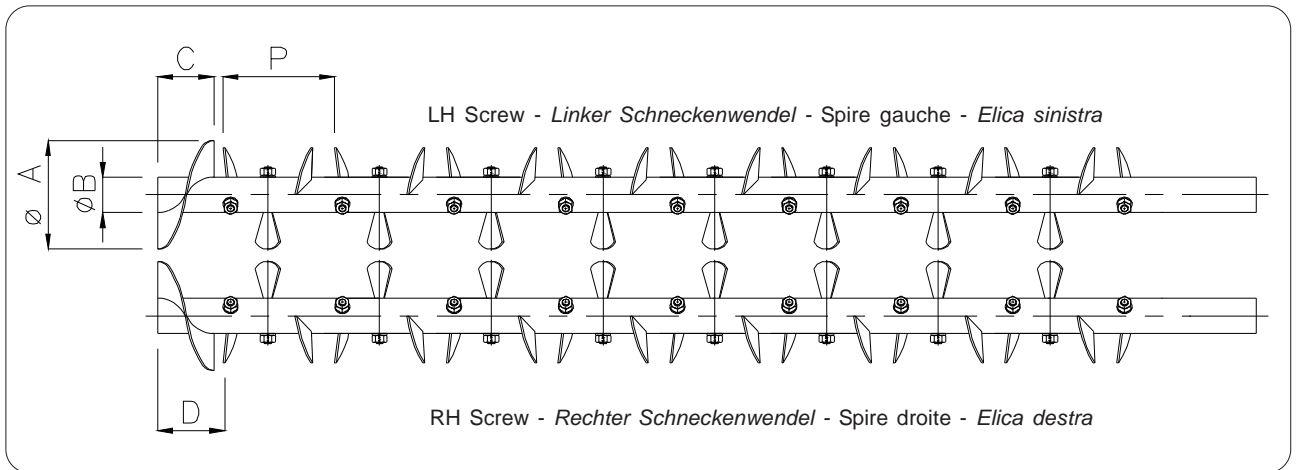

A1 type trapezoid paddles – 3 paddles per pitch
 Trapezpaddel Typ A1 – 3 Paddel pro Steigung
 Palettes en trapèzes type A1 - N°3 palettes par pas
 Palette trapezie tipo A1 - N° 3 palette al passo

Ø	A	B	C	D	P	kg
150	150	60	100	116	100	
200	200	60	100	122	133	
250	250	60	125	155	167	
300	300	114	150	185	200	
350	350	114	175	215	233	
400	400	114	200	145	267	
500	500	114	250	305	333	
600	600	168	300	365	400	

Contact the Manufacturer - *Beim Hersteller nachfragen*
 Consulter le Fabricant - *Consultare il Costruttore*

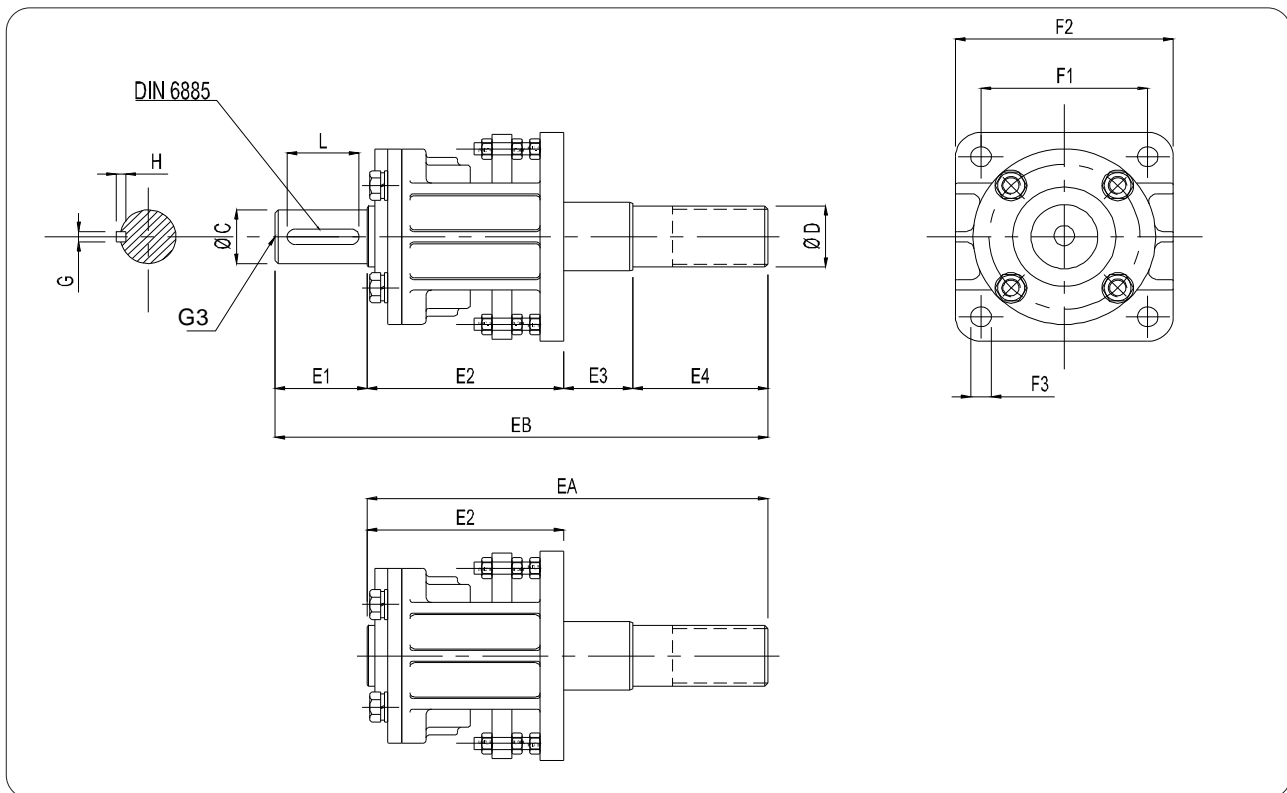

Code	Ø C UNI 6397	D DIN 5482	Z EA	V EB	E1	E2	E3	E4	F1	F2	F3	G3	GxHxL DIN 6885	kg
XSQ025 ..1	25	28 x 25	203	245	42	114	24	65	92	117	11	M10	8x7x36	5
XSQ035 ..1	35	40 x 36	252.5	310.5	58	124	43.5	85	105	137	13	M10	10x8x50	6.5
XSQ045 ..1	45	48 x 44	271.5	353.5	82	143	43.5	85	130	162	13	M12	14x9x70	14
XSQ055 ..1	55	60 x 55	304.5	386.5	82	151	43.5	110	149	210	18	M12	16x10x70	22
XSQ065 ..1	65	75 x 69	337.5	442.5	105	162	45.5	130	171	240	18	M16	18x11x90	32
XSQ080 ..1	80	90 x 84	410	540	130	180	60	170	198	250	22	M20	22x14x110	55

CodeA..B..E..	Seal Wellendichtung Etanchéité Tenuta
	Bearing Wälzlager Roulement Cuscinetto	Bearings Wälzlager Roulements Cuscinetti	Bearing Wälzlager Roulement Cuscinetto	
XSQ025 ..1	6206 - 2RS	6206 - 2RS	/	XUC 035
XSQ035 ..1	6206 - 2RS	6208 - 2RS	/	XUC 045
XSQ045 ..1	6206 - 2RS	6210 - 2RS	/	XUC 055
XSQ055 ..1	6206 - 2RS	6212 - 2RS	/	XUC 070
XSQ065 ..1	6206 - 2RS	6214 - 2RS	/	XUC 080
XSQ080 ..1	6206 - 2RS	6218 - 2RS	/	XUC 100

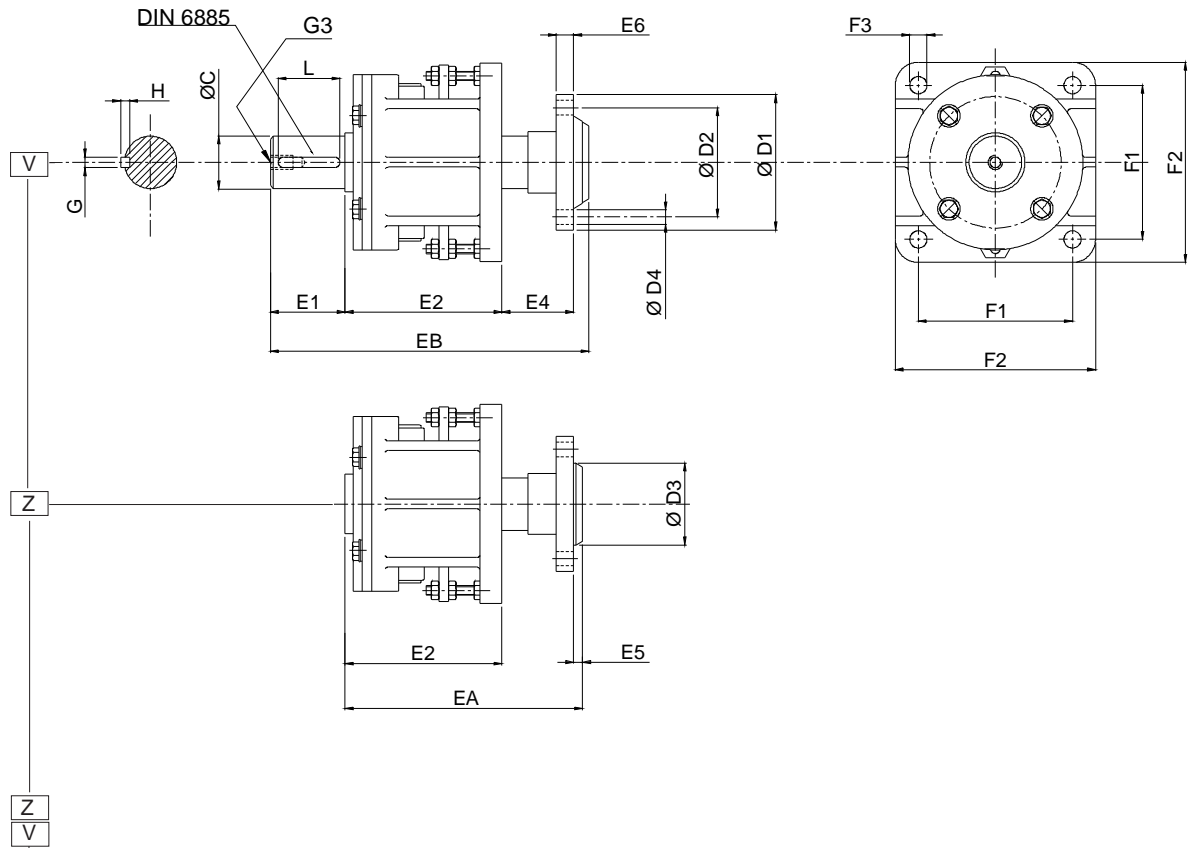

Code	Ø C UNI 6397	Ø D1	Ø D2	Ø D3	D4		EA	EB	E1	E2	E4	E5	E6	F1	F2	F3	GxHxL DIN 6885	G3	kg
					Ø	n													
XSS025 . . 1	25	95	70	50	10.5	4	162	204	42	114	55.5	2.5	10	92	117	11	8x7x36	M10	6
XSS035 . . 1	35	110	85	65	12.5	4	199.5	257.5	58	124	72.5	5.5	12	105	137	13	10x8x50	M10	8
XSS045 . . 1	45	130	100	78	16.5	4	226.5	308.5	82	143	84	9.5	12	130	162	13	14x9x70	M12	16
XSS055 . . 1	55	155	125	105	16.5	6	250.5	332.5	82	151	106.5	17.5	20	149	210	18	16x10x70	M12	26
XSS065 . . 1	65	155	125	105	16.5	6	263.5	368.5	105	162	106.5	17.5	20	171	240	18	18x11x90	M16	35
XSS080 . . 1	80	200	160	135	21	6	312	442	130	180	129	28	22	198	250	22	22x14x110	M20	62
XSS100 . . 1	100	235	190	160	25	6	396	561	165	230	135	38	25	266	340	30	28x16x140	M24	107

CodeA..B..E..	
	Bearing Wälzlager Roulement Cuscinetto	Bearings Wälzlager Roulements Cuscinetti	Bearing Wälzlager Roulement Cuscinetto	Seal Wellendichtung Etanchéité Tenuta
XSS025 . . 1	6206 - 2RS	6206 - 2RS	/	XUC 035
XSS035 . . 1	6206 - 2RS	6208 - 2RS	/	XUC 045
XSS045 . . 1	6206 - 2RS	6210 - 2RS	/	XUC 055
XSS055 . . 1	6206 - 2RS	6212 - 2RS	/	XUC 070
XSS065 . . 1	6206 - 2RS	6214 - 2RS	/	XUC 080
XSS080 . . 1	6206 - 2RS	6218 - 2RS	/	XUC 100
XSS100 . . 1	6222 - 2RS	6222 - 2RS	/	XUC 115

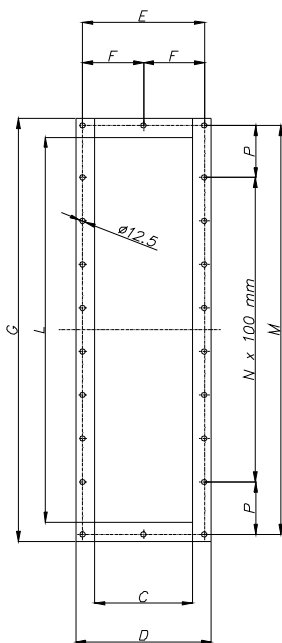
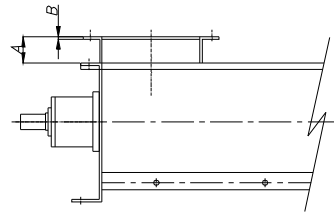

Fig.1

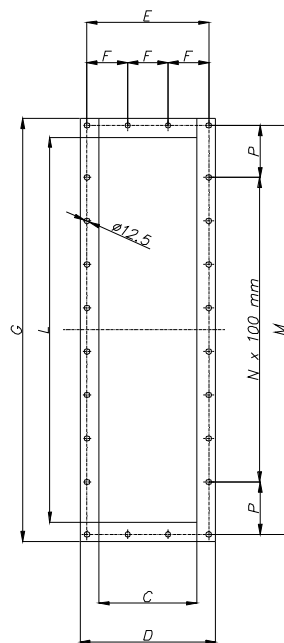

Fig.2

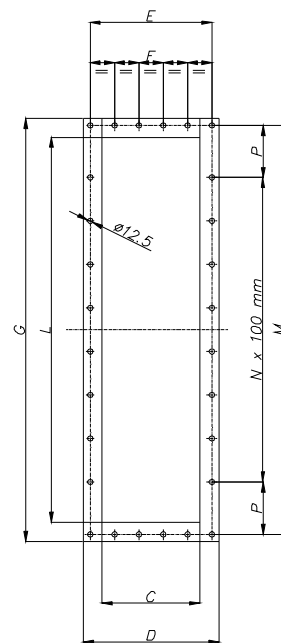

Fig.3

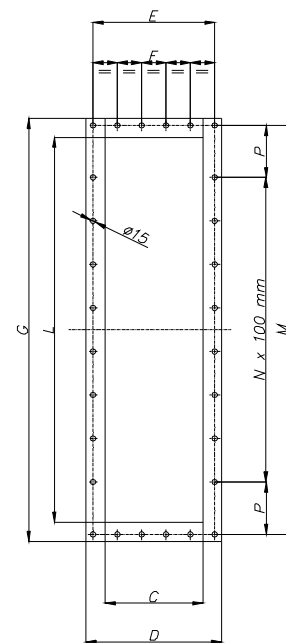
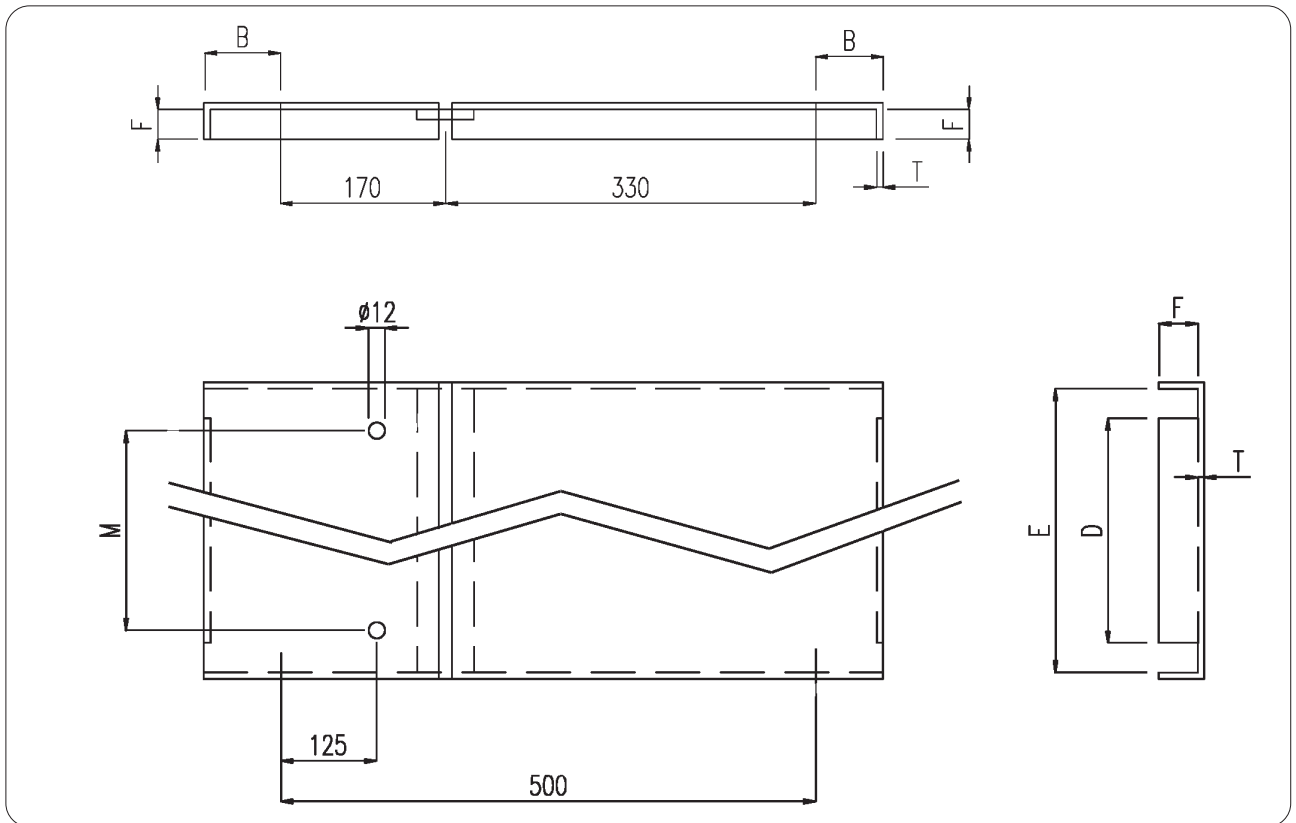

Fig.4

Ø	Fig.	A	B	C	D	E	F	G					L					M					N					P				
								2EL	3EL	4EL	5EL	6EL	2EL	3EL	4EL	5EL	6EL	2EL	3EL	4EL	5EL	6EL	2EL	3EL	4EL	5EL	6EL	2EL	3EL	4EL	5EL	6EL
150	1	60	3	175	251	230	115	433	598	763	923	1093	340	505	670	835	1000	395	560	725	890	1055	2	4	5	7	8	97.5	80	112.5	95	127.5
200	2	60	3	225	311	280	93.3	535	755	975	1195	1415	445	665	885	1105	1325	500	720	940	1160	1380	3	5	7	9	11	100	110	120	130	140
250	2	60	3	275	361	330	110	635	905	1175	1445	1715	545	815	1085	1355	1625	600	870	1140	1410	1680	4	6	9	12	15	100	135	120	105	90
300	2	60	4	325	433	385	128.3	755	1075	1395	1705	2035	645	965	1285	1605	1925	705	1025	1345	1665	1985	5	8	11	14	17	102.5	112.5	122.5	172.5	142.5
350	3	80	4	375	483	445	89	865	1245	1625	2005	2385	755	1135	1515	1895	2275	825	1205	1585	1965	2345	6	10	14	18	21	112.5	102.5	92.5	82.5	122.5
400	3	80	5	425	535	500	100	965	1390	1815	2240	2665	850	1275	1700	2125	2550	925	1350	1775	2200	2625	7	11	16	20	24	112.5	125	87.5	100	112.5
500	4	80	5	525	655	600	120	1175	1695	2215	2735	3253	1045	1665	2085	2605	3125	1120	1640	2160	2680	3200	9	14	19	24	30	110	120	130	140	100
600	4	80	5	625	755	700	140	1375	1995	2615	3235	3855	1245	1865	2485	3105	3725	1320	1940	2560	3180	3800	11	17	23	29	36	110	120	130	140	100

Contact the Manufacturer - *Beim Hersteller nachfragen*
 Consulter le Fabricant - *Consultare il Costruttore*



Ø	Code	B	D					E					F	M					T
			2 EL	3 EL	4 EL	5 EL	6 EL	2 EL	3 EL	4 EL	5 EL	6 EL		2 EL	3 EL	4 EL	5 EL	6 EL	
150	XFB_015051	50	338	503	668	833	998	436	601	766	931	1096	15	395	560	725	890	1055	2
200	XFB_020051	50	440	660	880	1100	1320	538	758	978	1198	1418	15	500	720	940	1160	1380	2
250	XFB_024051	60	540	810	1080	1350	1620	642	912	1182	1452	1722	15	600	870	1140	1410	1680	2
300	XFB_030051	60	640	960	1280	1600	1920	762	1082	1402	1722	2042	15	700	1015	1330	1645	1960	2
350	XFB_035051	60	750	1050	1350	1650	1950	872	1252	1632	2012	2392	15	825	1205	1585	1965	2345	2
400	XFB_040051	70	845	1270	1695	2120	2545	967	1392	1817	2242	2667	15	925	1350	1775	2200	2625	2
500	XFB_050051	70	1040	1560	2080	2600	3120	1182	1702	2222	2742	3262	15	1120	1640	2160	2680	3200	3
600	XFB_060051	70	1240	1860	2480	3100	3720	1382	2002	2622	3242	3862	15	1320	1940	2560	3180	3800	3

Contact the Manufacturer - *Beim Hersteller nachfragen*
 Consulter le Fabricant - *Consultare il Costruttore*

ORDER	BESTELLEN SIE	COMMANDEZ	ORDINARE
FNCO: if only the limit switch mount is required	FNCO: nur für Halterung ohne Endschalter	FNCO: uniquement avec le support de fin de course	FNCO: se si vuole soltanto la basetta fine corsa
FNC9: if both limit switch and mount are required	FNC9: für Halterung inkl. Endschalter	FNC9: avec le fin de course et son support	FNC9: se si vuole basetta e fine corsa

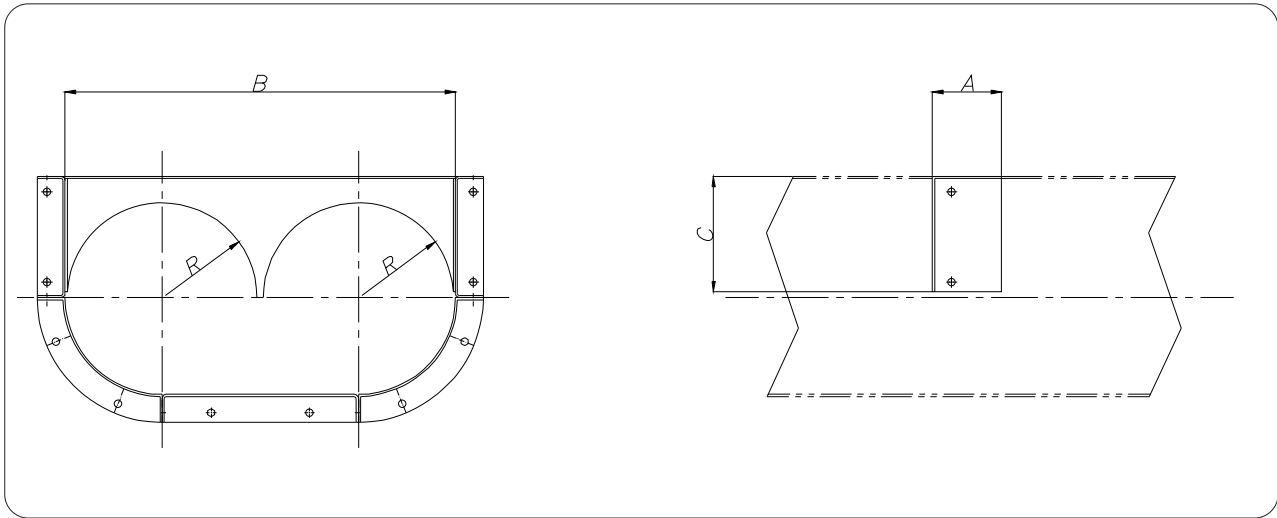

Code	Ø	A	B					C	R
			2 EL	3 EL	4 EL	5 EL	6 EL		
XJE015_ _ _	150	100	340	505	670	835	1000	110	87.5
XJE020_ _ _	200	100	445	665	885	1105	1325	130	112.5
XJE025_ _ _	250	120	545	815	1085	1355	1625	150	137.5
XJE030_ _ _	300	120	645	965	1285	1605	1925	190	162.5
XJE035_ _ _	350	120	755	1135	1515	1895	2275	230	187.5
XJE040_ _ _	400	140	850	1275	1700	2125	2550	260	212.5
XJE050_ _ _	500	140	1045	1565	2085	2605	3125	330	262.5
XJE060_ _ _	600	140	1245	1865	2485	3105	3725	410	312.5

Contact the Manufacturer - *Beim Hersteller nachfragen*
 Consulter le Fabricant - *Consultare il Costruttore*

Type _____ X J E 0 2 0 U 2 1

Ø Machine - Ø Maschin _____
 Ø Machine - Ø Macchina _____

U = _____
 V = _____

Ø of screws - *Wendelzahl*
 Ø Hélices - Ø Eliche _____

Material - *Werkstoff* _____
 Material - *Materiale* _____

1= Fe
 2 = 304L st. st. - 1.4306 - Inox 304L - Aisi 304L
 3 = 316L st. st. - 1.4404 - Inox 316L - Aisi 316L

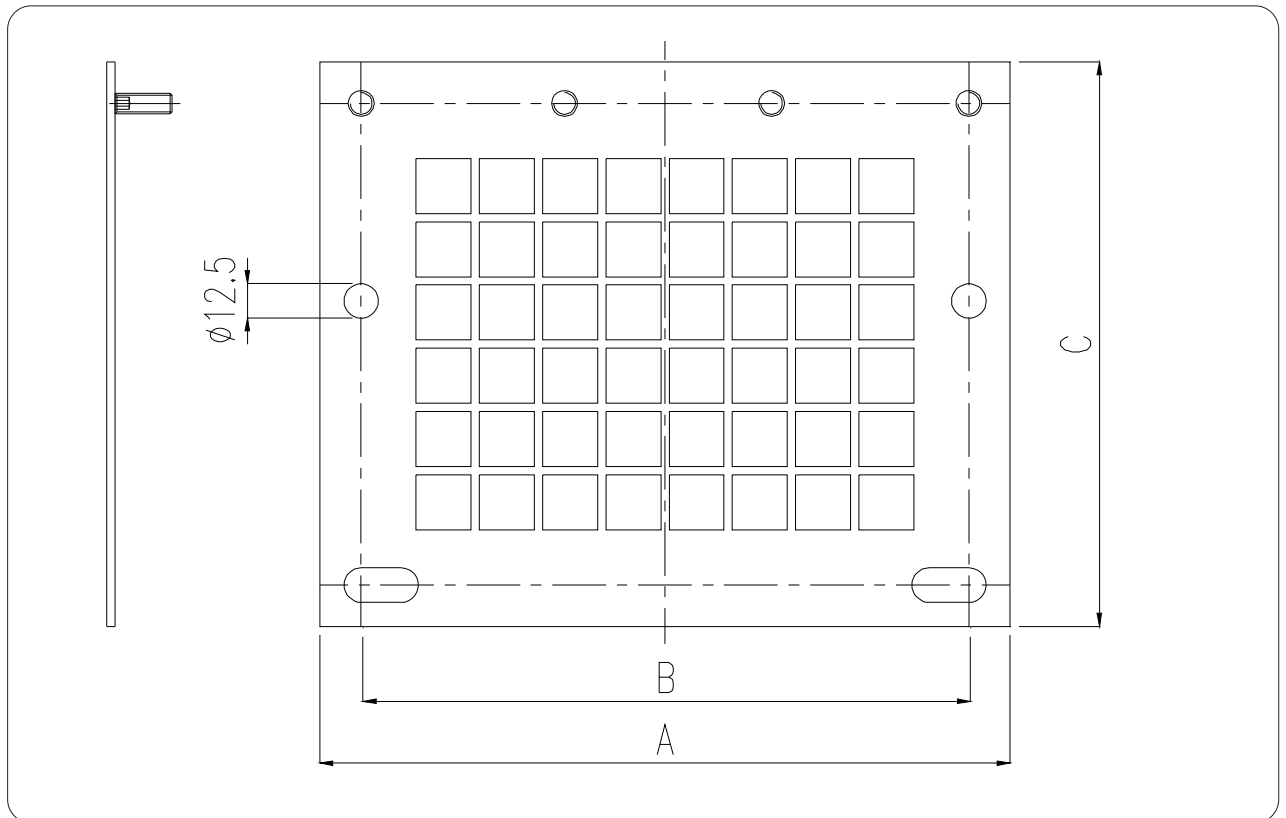

Ø	CODE	A					B					C
		2 EL	3 EL	4 EL	5 EL	6 EL	2 EL	3 EL	4 EL	5 EL	6 EL	
150	XKX _ _ _ _	428	593	758	923	1088	395	560	725	890	1055	350
200	XKX _ _ _ _	533	753	973	1193	1413	500	720	940	1160	1380	350
250	XKX _ _ _ _	633	903	1173	1443	1713	600	870	1140	1410	1680	350
300	XKX _ _ _ _	753	1073	1393	1713	2033	705	1025	1345	1665	1985	350
350	XKX _ _ _ _	867	1247	1627	2007	2387	825	1205	1585	1965	2345	350
400	XKX _ _ _ _	962	1387	1812	2237	2662	925	1350	1775	2200	2625	350
500	XKX _ _ _ _	1177	1697	2217	2737	3257	1120	1640	2160	2680	3200	350
600	XKX _ _ _ _	1377	1997	2617	3237	3857	1320	1940	2560	3180	3800	350

Contact the Manufacturer - *Beim Hersteller nachfragen*
 Consulter le Fabricant - *Consultare il Costruttore*

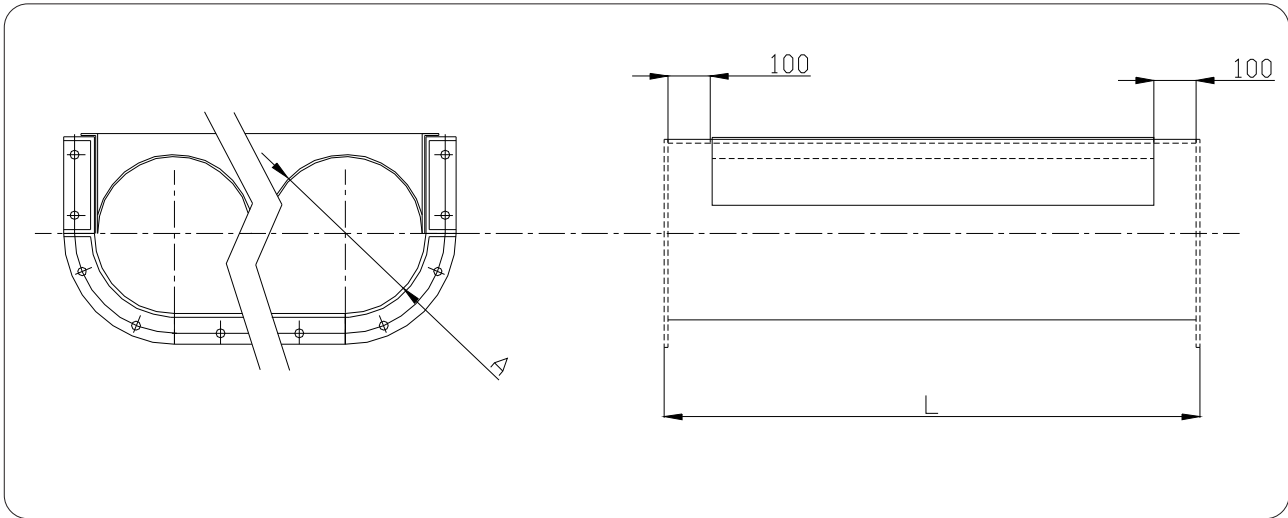

Code	Ø	A
XJG015_ _ _ _ _	150	175
XJG020_ _ _ _ _	200	225
XJG025_ _ _ _ _	250	275
XJG030_ _ _ _ _	300	325
XJG035_ _ _ _ _	350	375
XJG040_ _ _ _ _	400	425
XJG050_ _ _ _ _	500	525
XJG060_ _ _ _ _	600	625

Contact the Manufacturer - *Beim Hersteller nachfragen*
 Consulter le Fabricant - *Consultare il Costruttore*

* L = 500 - 1000 - 1500 - 2000 - 2500 - 3000 mm

Type _____ X J G 0 1 5 1 0 U 2 1

Ø Machine - Ø Maschin
 Ø Machine - Ø Macchina

L _____ (dm)

U = _____
 V = _____

Ø of screws - *Wendelzahl*
 Ø Hélices - Ø *Eliche*

Material - *Werkstoff*
 Material - *Materiale*

1= Fe
 2 = 304L st. st. - 1.4306 - Inox 304L - Aisi 304L
 3 = 316L st. st. - 1.4404 - Inox 316L - Aisi 316L

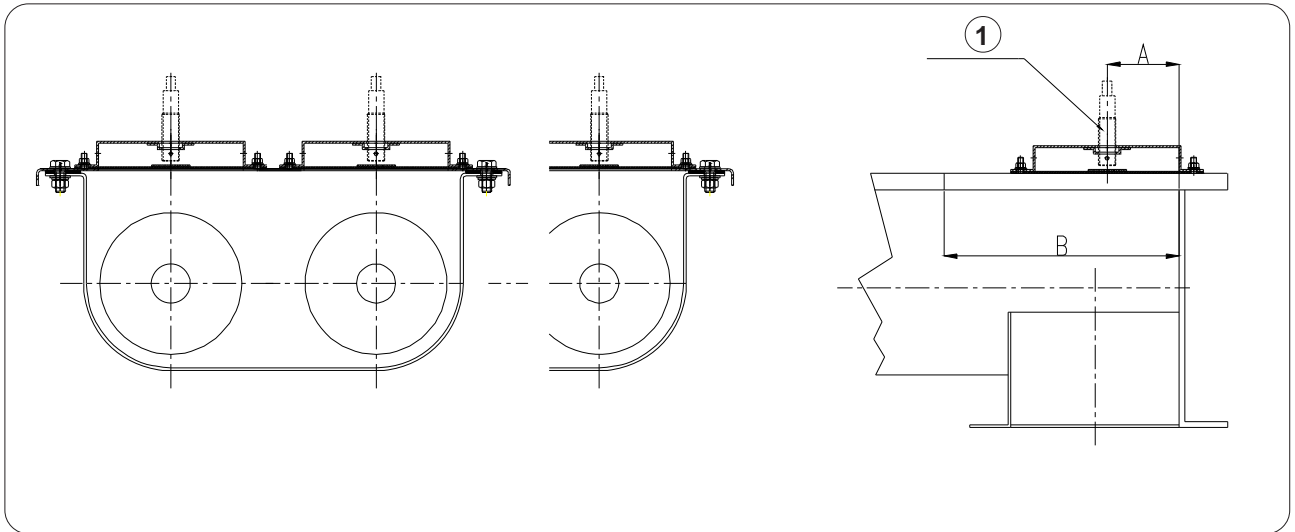

- ① Inductive sensor excluded from supply
Induktionssensor vom Lieferumfang ausgeschlossen
 Capteur à induction exclu de la fourniture
 Sensore induttivo escluso dalla fornitura

Ø	Code	A	B
150	XKYM151_	75	500
200	XKYM201_	75	500
250	XKYM251_	125	500
300	XKYM301_	125	500
350	XKYM351_	125	500
400	XKYM401_	200	500
500	XKYM501_	200	500
600	XKYM601_	200	500

Number of screws
 Anzahl Schrauben
 Nombre de spires
 Numero di eliche

 Contact the Manufacturer - *Beim Hersteller nachfragen*
 Consulter le Fabricant - *Consultare il Costruttore*

N.B.: The overflow hatch flap can be fitted with a fine pitch M18 normally closed inductive sensor
 The number of accessories required is equal to the number of screws
Die Klappe ist für die Montage eines Induktionssensors mit Öffnerkontakt M18 Feinsteigung vorgerüstet.
Man braucht so viele Zubehörteile, wie es Wendel gibt.
 Le capot est prévu pour le montage d'un capteur à induction normalement fermé M18 à pas fin.
 Il faut qu'il y ait autant d'accessoires que de nombre de spires
Il portello è predisposto per il montaggio di un sensore induttivo normalmente chiuso M18 passo fine
Sono necessari tanti accessori quante sono le spire

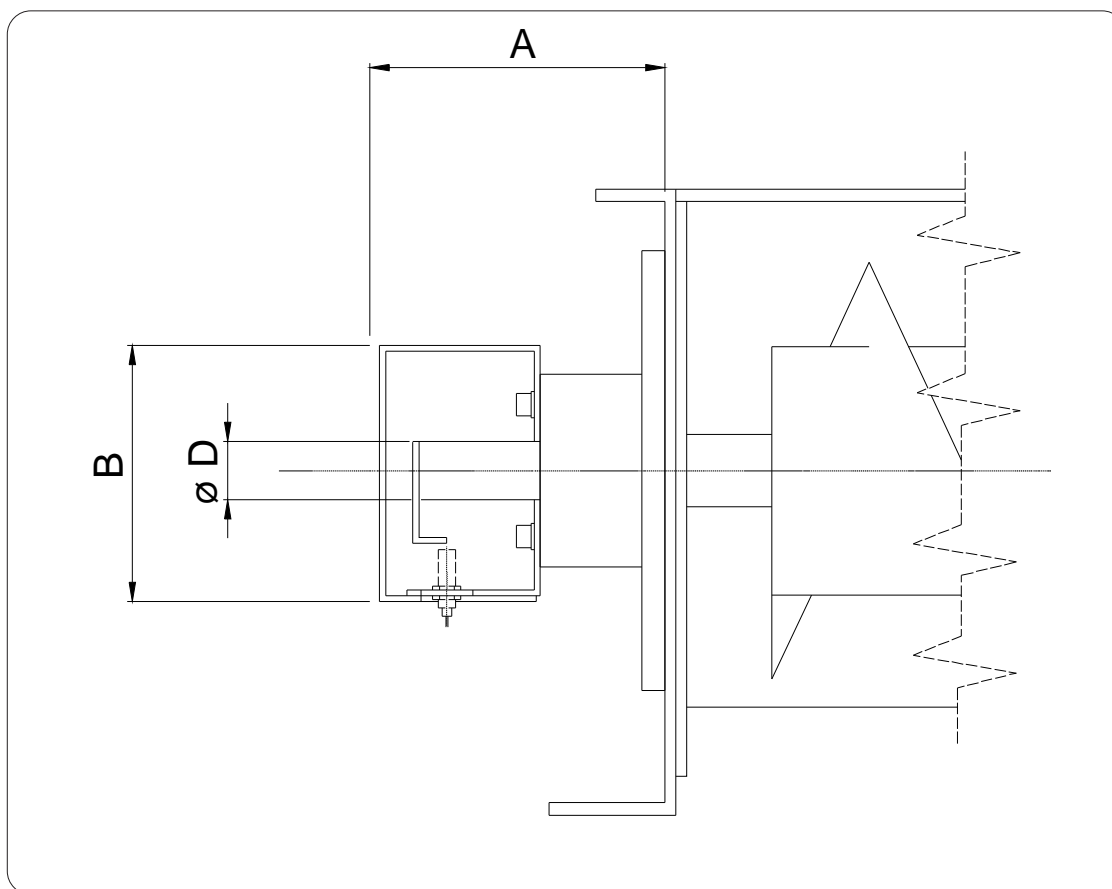

Code	A	B	ø D
XVAPV0251	170	140	25
XVAPV0351	210	170	35
XVAPV0451	240	200	45
XVAPV0551	240	230	55
XVAPV0651	300	290	65
XVAPV080	340	320	80
XVAPV1001	430	350	100

The indicator bracket is sized for a fine pitch normally closed M 30 inductive sensor.

Der Sockel ist für einen Induktionssensor mit Öffnerkontakt M30 mit feiner Teilung ausgelegt.

La base est dimensionnée pour un détecteur inductif normalement fermé M 30 à pas fin.

La basetta è dimensionata per un sensore induttivo normalmente chiuso M 30 passo fine.

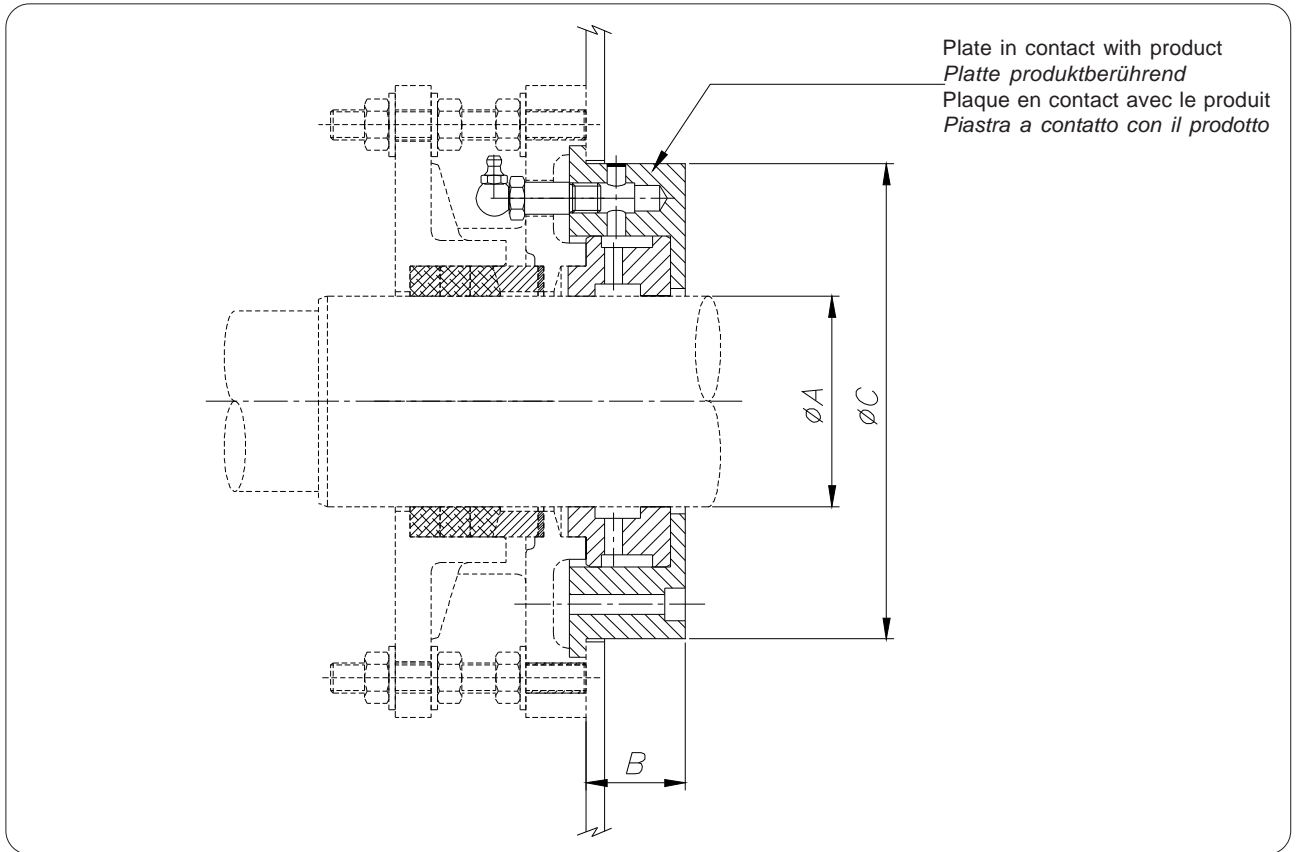

Code	Ø A	B	Ø C	Suitable for - Passend zu Pour type - Idoneo per	kg
XUJ0305_	030			S 21	
XUJ0355_	035		99	XS_025_	
XUJ0405_	040			S 23	
XUJ0455_	045		113	XS_035_	
XUJ0505_	050			S 25	
XUJ0555_	055		134	XS_045_	
XUJ0605_	060			S 27	
XUJ0705_	070		158	XS_055_	
XUJ0805_	080		158	XS_065_	
XUJ1005_	100		203	XS_080_	
XUJ11551	116	55	238	XS_100_1	
XUJ13551	136			XS_120_1	

X	U	J					
----------	----------	----------	--	--	--	--	--

Ø A (mm)

Type of seal - Dichtungstyp - Type d'étanchéité - Tipo tenuta
 2 Water - Wasser - Eau - Acqua
 5 Grease - Fett - Graisse - Grasso
 6 Air - Luft - Air - Aria (0,2 bar)

Material of plate in contact with product - Werkstoff der produktberührenden Platte
Matériau de la plaque en contact avec le produit - Materiale piastra a contatto con il prodotto
 1= Carbon steel - Normalstahl
 Acier au carbone - Acciaio al carbonio
 2= 304L st. st. - 1.4306 - Innox 304L - Aisi 304L
 3= 316L st. st. - 1.4404 - Innox 316L - Aisi 316L

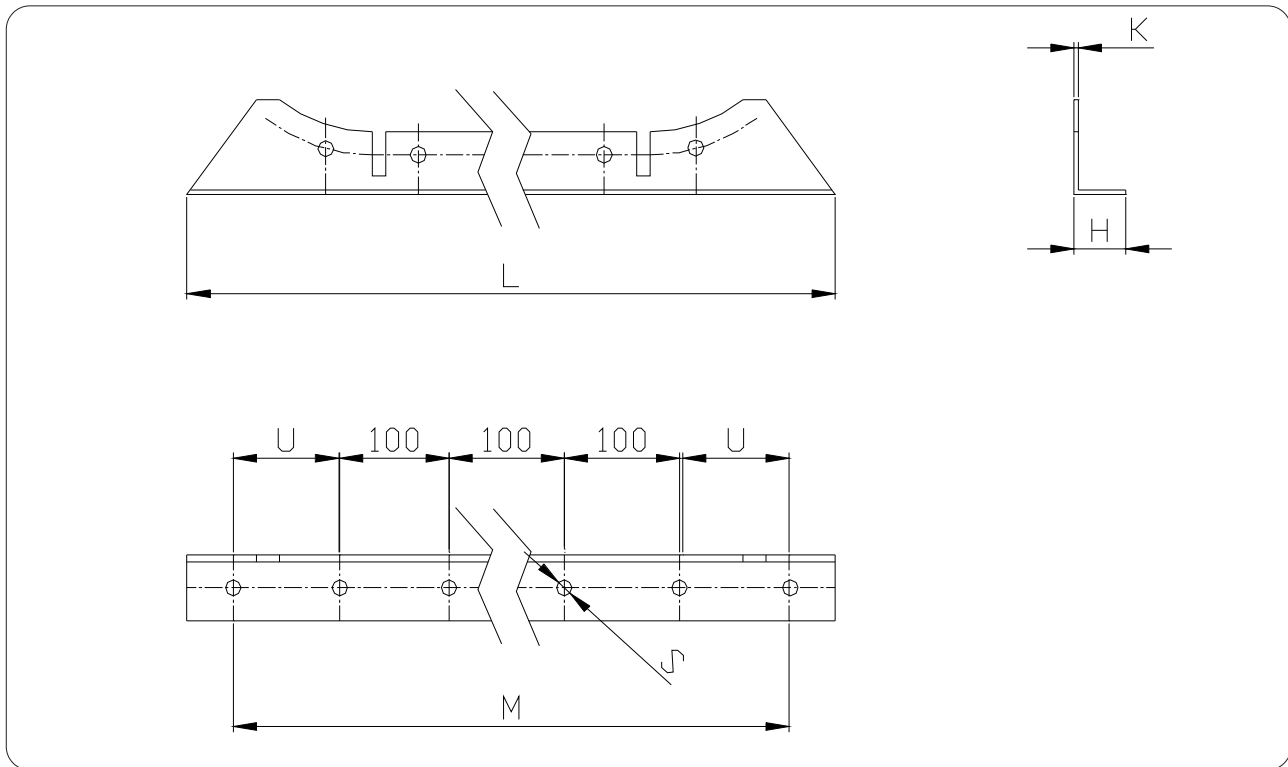

Ø	CODE	L					M					U					H	K	S	Z
		2EL	3EL	4EL	5EL	6EL	2EL	3EL	4EL	5EL	6EL	2EL	3EL	4EL	5EL	6EL				
150	XJ_0151	433	598	763	928	1093	395	560	725	890	1055	97.5	80	112.5	95	127.5	50	5	12.5	12.5
200	XJ_0201	535	755	975	1195	1415	500	720	940	1160	1380	100	110	120	130	140	50	6	12.5	15
250	XJ_0251	635	905	1175	1445	1715	600	870	1140	1410	1680	100	135	120	105	90	70	6	12.5	15
300	XJ_0301	750	1065	1380	1695	2010	705	1025	1345	1865	1705	105	117.5	130	142.5	155	70	6	12.5	19
350	XJ_0351	865	1245	1625	2005	2385	825	1205	1585	1965	2345	112.5	102.5	92.5	82.5	122.5	70	8	12.5	19
400	XJ_0401	965	1390	1815	2240	2665	925	1350	1775	2200	2625	112.5	125	87.5	100	112.5	80	8	12.5	19
500	XJ_0501	1175	1695	2215	2735	3255	1120	1640	2160	2680	3200	110	120	130	140	100	90	10	15	24
600	XJ_0601	1375	1995	2615	3235	3855	1320	1940	2560	3180	3800	110	120	130	140	100	100	10		24

Contact the Manufacturer - *Beim Hersteller nachfragen*
 Consulter le Fabricant - *Consultare il Costruttore*

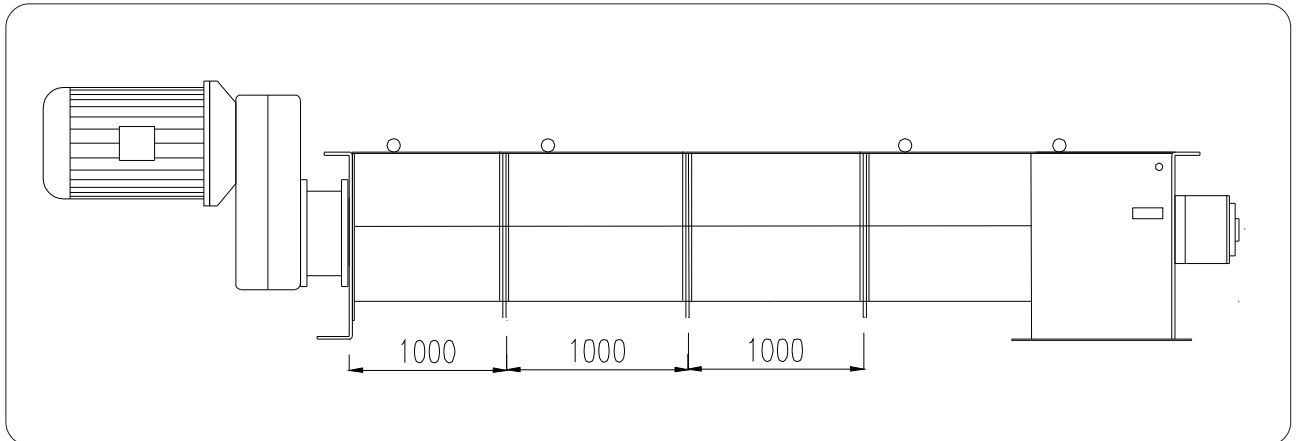

Live Bin Bottoms must always have adequate support. The reinforcement rings are accessories used for stiffening the structure so that it provides support especially when the puller screws have to support very heavy weight.

hts.

Geometry and shape of MU Live Bin Bottoms are in conformity with a material discharging device. MU Live Bin Bottoms are not sized to perform structural support functions of a bin, hopper or silo bottom. It is the plant fitter's responsibility to support the silo, hopper or bin in a correct fashion. **MU Live Bin Bottoms have to be supported at both ends and in the intermediate section.** The number of supports in the intermediate section has to be defined by the plant fitter depending on the quantity of material weighing on the MU Live Bin Bottom.

Austragschneckenböden müssen immer in angemessener Weise gelagert werden. Die Verstärkungsringe sind Zubehörteile, die dazu dienen, die Struktur zu versteifen und die Unterstützung zu erleichtern, insbesondere dann, wenn ein hohes Gewicht auf den Schneckenwendeln lastet.

Geometrie und Form der MU Schneckenaustragsböden entsprechen allein der Anforderung, ein Schüttgut auszutragen. MU Schneckenaustragsböden sind nicht dafür ausgelegt, eine Abstützfunktion des jeweiligen Trichters, Behälters oder Silos zu erfüllen. Es liegt in der Verantwortung des Anlagenaufstellers, den Trichter, Behälter oder Silo in angemessener Weise abzustützen. **MU Schneckenaustragsböden müssen sowohl an beiden Enden, als auch im mittleren Abschnitt abgestützt werden.** Die Anzahl der Abstützungen im mittleren Abschnitt ist vom Anlagenaufsteller festzulegen und hängt in jedem Fall von der Materialmenge ab, welche auf dem MU Schneckenaustragsboden lastet.

Les extracteur multiples doivent toujours être soutenus de manière adéquate.

Les anneaux de renforts sont des accessoires servant à maintenir la structure rigide et faciliter la fonction de support surtout quand les extracteurs doivent soutenir des poids élevés.

La géométrie et la forme des extracteurs multiples à vis sont dimensionnés comme système pour l'extraction du produit. Les MU ne sont donc pas dimensionnés pour mener la fonction structurale de fond d'une trémie, ou d'un silo ou de n'importe quel autre type de récipient. Il est la responsabilité de l'installateur de supporter l'extracteur MU correctement. **L'extracteur MU doit être supporté aux deux extrémités et dans la partie intermédiaire.** Le nombre de supports dans la partie intermédiaire doit être défini par l'installateur en fonction du poids du matériau gravant sur l'extracteur-même.

Gli estrattori multipli devono essere sempre adeguatamente supportati. Gli anelli di rinforzo sono accessori utili ad irrigidire la struttura e a facilitare l'opera di supporto specialmente quando sugli estrattori gravano pesi elevati.

La geometria e la forma dell'MU sono dimensionati come sistema per l'estrazione del prodotto. L'MU quindi non è dimensionato per svolgere la funzione strutturale di fondo di una tramoggia, di un silo o di qualunque altro contenitore. Sarà cura dell'installatore supportarlo correttamente. **L'estrattore MU deve essere supportato alle due estremità e nel tratto intermedio.** Il numero di supporti nel tratto intermedio dovrà essere definito dall'installatore in funzione del peso del materiale gravante sull'estrattore stesso.

Ø	Code
150	
200	
250	
300	
350	
400	
500	
600	



Contact the Manufacturer - *Beim Hersteller nachfragen*
 Consulter le Fabricant - *Consultare il Costruttore*

Nbr. of screws - *Wendelzahl*
 N° de spires - *N° spire*

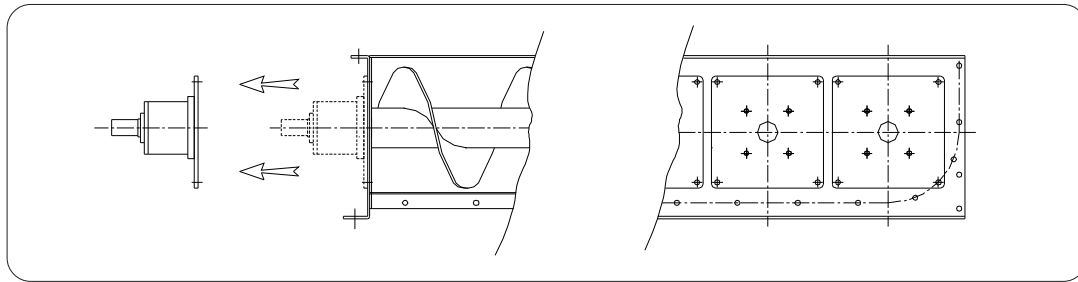

This option makes it possible to remove the screws separately from the opposite side of the MTR. The screw is extracted axially through an opening made on the end plate.

The operation is possible without having to disconnect any part of the MU from the frame (hopper, supports, or other parts) connected to it.

The splined couplings facilitate this removal further since it is not necessary to work inside the MU to remove or unscrew bolted or flanged connecting bolts.

Diese Option ermöglicht das schnelle Herausziehen der einzelnen Wendeln auf der Seite gegenüber dem Antrieb. Die Wendel wird axial durch eine Öffnung herausgezogen, die im Lager-Endschild vorgesehen ist. Der Vorgang kann durchgeführt werden, ohne irgendein Teil des MU-Austragbodens von den mit ihm verbundenen Strukturen (Trichter, Träger u.ä.) abtrennen zu müssen.

Die Evolventenkeilwellenverbindungen vereinfachen das Herausziehen darüber hinaus, da man nicht im Bodeninneren arbeiten muss, um etwaige verstiftete oder geflanschte Schraubbolzen zu entfernen oder loszuschrauben.

Cette option permet l'extraction des spires par le côté opposé à celui de la MTR.

La spire est retirée dans la direction axiale à travers une ouverture faite sur la flasque porte paliers

L'opération est réalisable sans devoir désolidariser aucune partie de l'extracteur MU des structures (trémie, supports ou autre) qui lui sont reliées.

Les accouplements emboîtés facilitent encore plus l'opération de dépose, car il ne faut pas intervenir à l'intérieur du MU pour enlever ou dévisser des boulons d'accouplement broché ou fixé par bride.

Questa opzione permette l'estraibilità delle singole spire dal lato opposto a quello della MTR.

La spira viene sfilata assialmente attraverso una apertura praticata sulla piastra portasupporti. L'operazione è fattibile senza dover sconnettere alcuna parte dell'MU dalle strutture (tramogga, sostegni o altro) ad esso collegate.

Gli accoppiamenti calettati facilitano ulteriormente l'operazione di sfilo non dovendo operare all'interno dell'MU per togliere o svitare eventuali bulloni di accoppiamento spinato o flangiato.

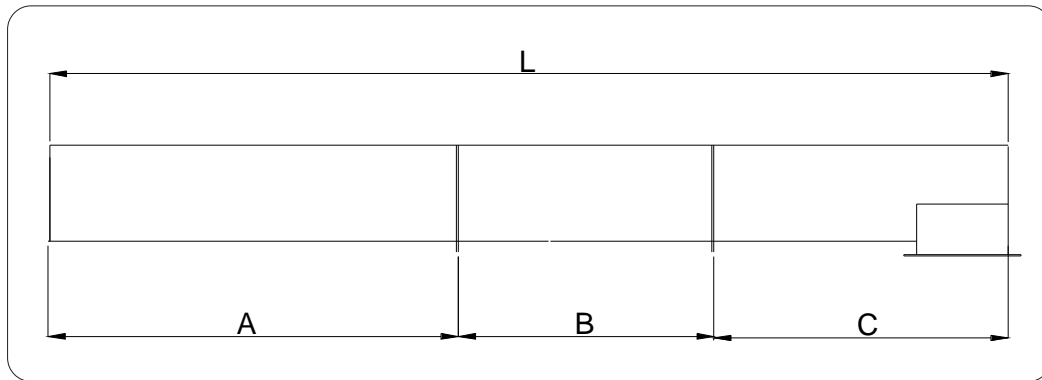

Length L = (end flange to end flange) is multiple of 500 mm.

Länge L = (Endflansch-Endflansch) ist ein Vielfaches von 500 mm.

Longueur entre flasques multiple de 500 mm.

La lunghezza flangia - flangia L è multipla di 500 mm.

Ø 150 ÷ 400 mm

L	A					B					C		L MAX for - für pour - per
	1000	1500	2000	2500	3000	1000	1500	2000	2500	3000	1000	1500	
1500													Ø 150
2000	1										1		
2500		1									1		
3000			1								1		
3500				1							1		
4000					1						1		Ø 200-250
4500					1							1	
5000					1	1					1		
5500					1		1				1		Ø 350-400
6000					1			1			1		
6500					1				1		1		Ø 300

Ø 500 ÷ 600 mm

L	A					B					C		L MAX for - für pour - per
	1000	1500	2000	2500	3000	1000	1500	2000	2500	3000	1500	2000	
2000												1	Ø 500
2500	1										1		
3000		1									1		
3500			1								1		
4000				1							1		
4500					1						1		
5000					1							1	
5500					1	1					1		
6000					1		1				1		
6500					1			1			1		Ø 600
7000					1				1		1		

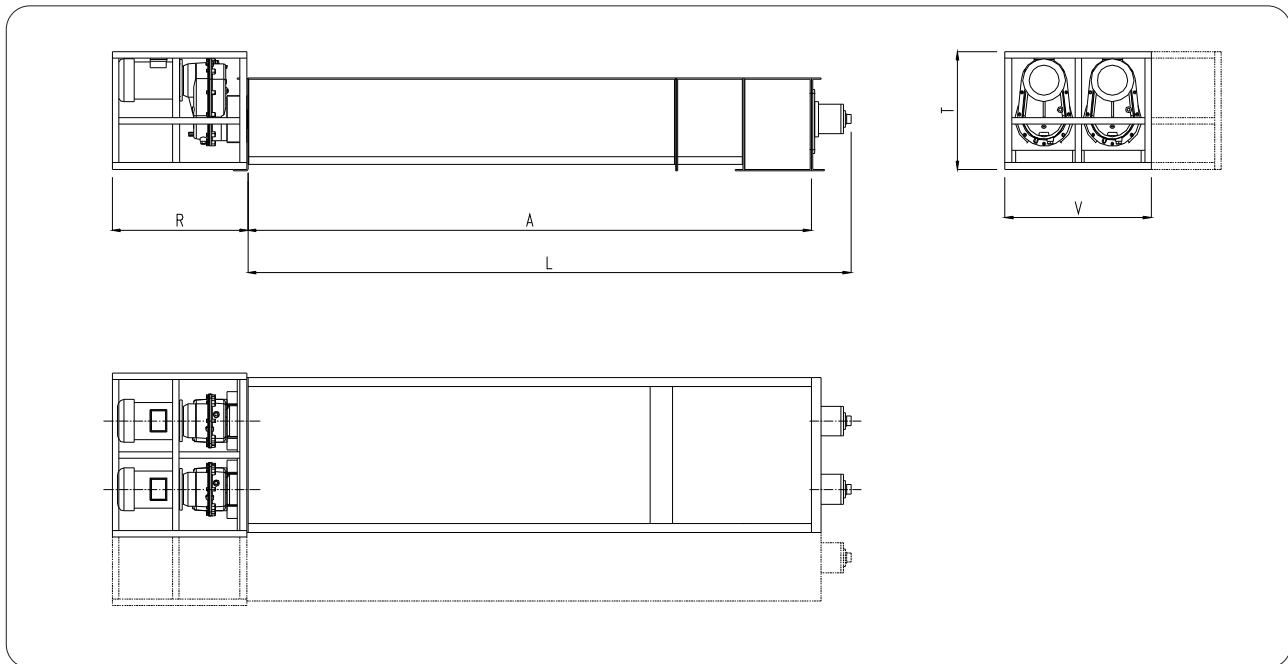

Ø	L MAX	R MAX	T MAX	V				
				2EL	3EL	4EL	5EL	6EL
150	A + 200	700	650	500	650	850	1000	1200
200	A + 230			600	850	1050	1250	1500
250				700	975	1250	1525	1800
300	A + 270	1000	750	850	1160	1475	1800	2100
350			800	1000	1375	1750	2125	2500
400	A + 300			1100	1525	1950	2375	2800
500			900	1250	1790	2325	2870	3400
600	A + 400	1000	1500	2125	2750	3375	4000	

N.B.: it may be necessary to separate the puller screw into a number of sections, with the drive unit separated, for transport.

N.B: Aus Transportgründen kann es erforderlich sein, den Aus-tragboden in mehrere Teile zerlegt und die Antriebseinheit getrennt zu liefern.

N.B: Pour des raisons de transport il peut s'avérer nécessaire de décomposer l'extracteur en plusieurs sections et avec le groupe motorisation séparé.

N.B.: per ragioni di trasporto può rendersi necessario dividere l'estrattore in più sezioni e con il gruppo motorizzazione separato.

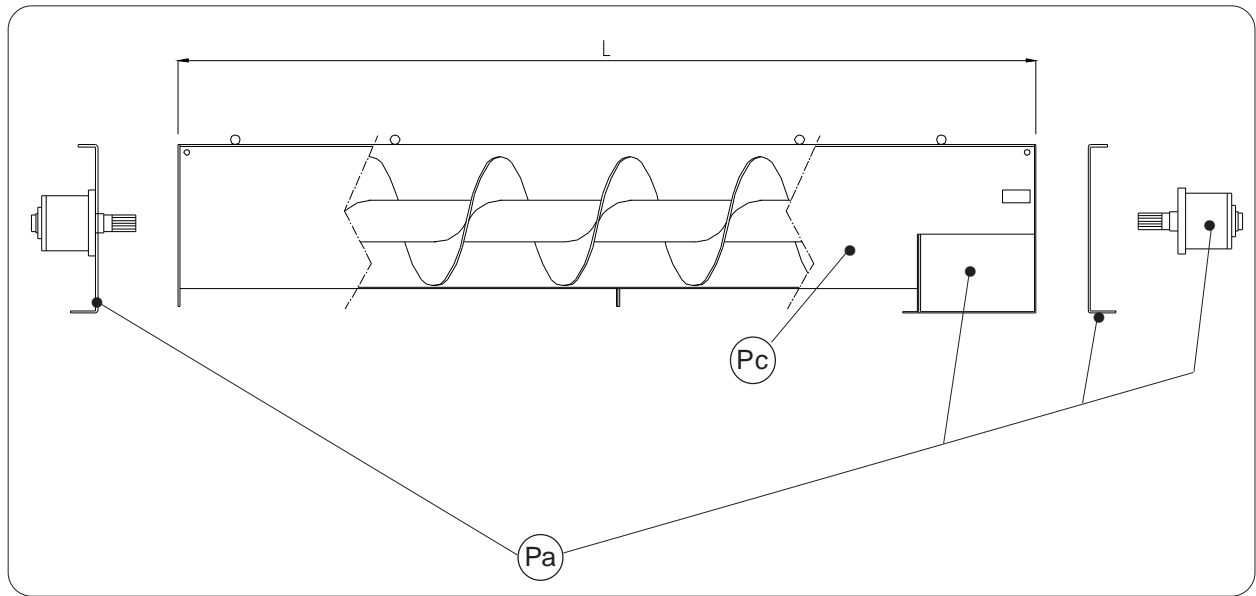
**N = 2**

$$P t = P a + (P c \cdot L)$$

P t = Total weight / Gesamtgewicht / Poids total / Peso totale (kg)

L = Length / Länge / Longueur / Lunghezza (m)

N = n° screws / n° Schneckenwendel \ n° spire \ Numero spire

Ø	150	200	250	300	350	400	500	600
Pa	43.8	52.8	98	145	180	330	330	480
Pc	22.5	27.7	32.2	49	55.6	79.6	79.6	102

For machines with more than two screws consult the tables below for the weights.

Für die Maschinen mit mehr als zwei Wendeln sind die Gewichte der folgenden Tabelle zu entnehmen.

Pour les machines dont le nombre de spires est supérieur à deux, calculer le poids à partir de la table ci-dessous.

Per macchine con n° di eliche superiore a due ricavare i pesi dalla tabella sottostante.

N > 2

$$P t^1 = P t + (N - 2) \times P a^1 + (N - 2) \times (P c^1 \times L)$$

P t¹ = Total weight / Gesamtgewicht / Poids total / Peso totale (kg)

L = Length / Länge / Longueur / Lunghezza (m)

N = n° screws / n° Schneckenwendel \ n° spire \ Numero spire

Ø	150	200	250	300	350	400	500	600
Pa¹	18.6	22.2	42	62.5	75	103	136	214
Pc¹	16.8	19.4	23.2	36.7	41.3	45.9	55	67

If the equipment is shipped in a packing case or crate add the weight of the packing to the weight of the equipment.

Wird das Gerät in einer Kiste oder einem Verslag zum Versand gebracht, ist das Gewicht der Verpackung zum Gewicht der Schnecke zu addieren.

Si la machine est expédiée emballée en caisse ou cage, ajouter le poids de l'emballage au poids total de la vis sans fin.

Se la macchina è spedita imballata in cassa o gabbia, al peso totale della stessa aggiungere il peso dell'imballo.

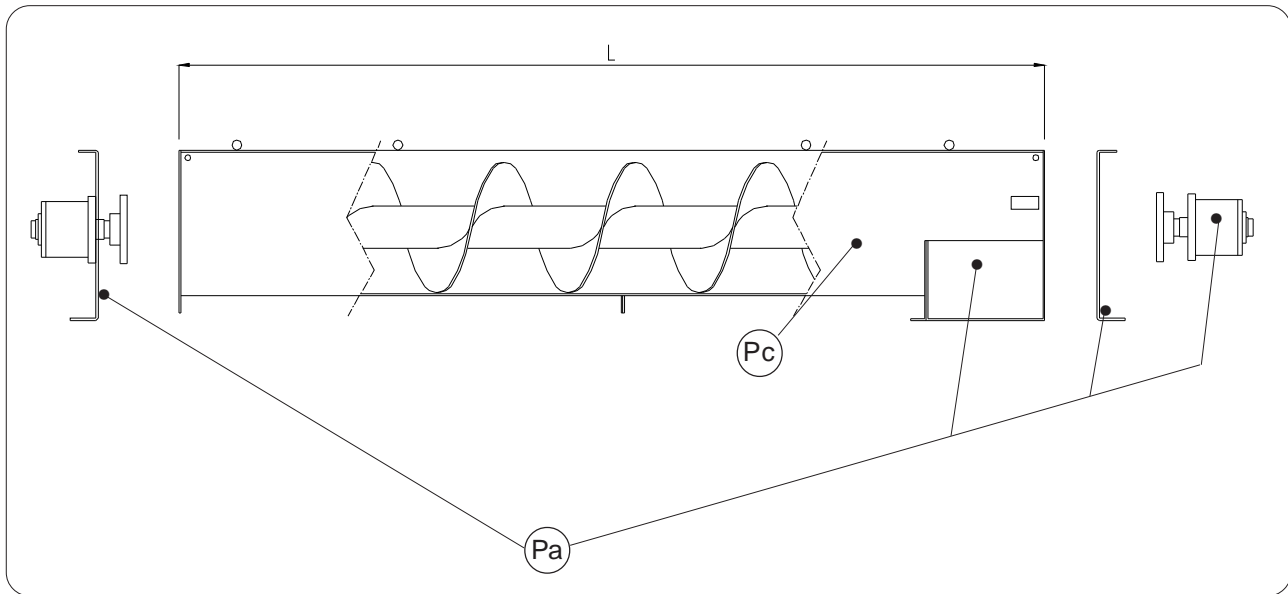

N = 2

$$P t = P a + (P c \cdot L)$$

P t = Total weight / Gesamtgewicht / Poids total / Peso totale (kg)

L = Length / Länge / Longueur / Lunghezza (m)

N = n° screws / n° Schneckenwendel \ n° spire \ Numero spire

Ø	200	250	300	350	400	500	600
Pa	58.8	106	160	196	252	342	500
Pc	35.8	43	71.3	80.6	91.1	111.3	132.5

For machines with more than two screws consult the tables below for the weights.

Für die Maschinen mit mehr als zwei Wendeln sind die Gewichte der folgenden Tabelle zu entnehmen.

Pour les machines dont le nombre de spires est supérieur à deux, calculer le poids à partir de la table ci-dessous.

Per macchine con n° di eliche superiore a due ricavare i pesi dalla tabella sottostante.

N > 2

$$P t^1 = P t + (N - 2) \times P a^1 + (N - 2) \times (P c^1 \times L)$$

P t¹ = Total weight / Gesamtgewicht / Poids total / Peso totale (kg)

L = Length / Länge / Longueur / Lunghezza (m)

N = n° screws / n° Schneckenwendel \ n° spire \ Numero spire

Ø	200	250	300	350	400	500	600
Pa¹	25	46	71	83.8	110	144	226
Pc¹	24.3	29.8	48.3	55	60	70	85

If the equipment is shipped in a packing case or crate add the weight of the packing to the weight of the equipment.

Wird das Gerät in einer Kiste oder einem Verschlag zum Versand gebracht, ist das Gewicht der Verpackung zum Gewicht der Schnecke zu addieren.

Si la machine est expédiée emballée en caisse ou cage, ajouter le poids de l'emballage au poids total de la vis sans fin.

Se la macchina è spedita imballata in cassa o gabbia, al peso totale della stessa aggiungere il peso dell'imballo.

N.B. Rights reserved to modify technical specifications

N.B. Angaben ohne Gewähr. Änderungen können ohne Vorankündigung vorgenommen werden.

N.B. Toutes données portées dans le présent catalogue n'engagent pas le fabricant. Elles peuvent être modifiées à tout moment.

N.B. Tutti i dati riportati nel presente catalogo non sono impegnativi e possono subire variazioni in qualsiasi momento.



WAM®

WAM S.p.A.
Via Cavour, 338
I - 41030 Ponte Motta
Cavezzo (MO) - ITALY

 + 39 / 0535 / 618111
fax + 39 / 0535 / 618226
e-mail info@wamgroup.it
internet www.wamgroup.com
videoconferenze + / 39 / 0535 / 49032